

TTX SERIES actuators

**CURTISS -
WRIGHT**

Installation & Service Instructions

Rev. C | PN75667 | 7/30/20

EXLAR[®]

TTX080 48 Vdc Models

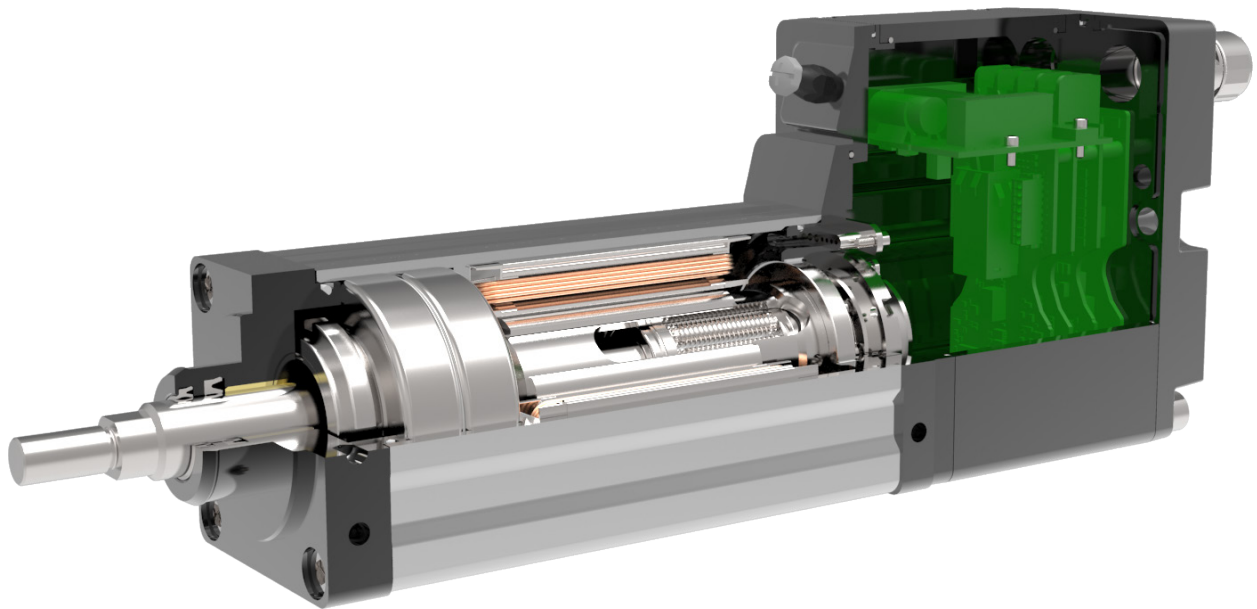

This document does not contain any export-controlled technical data.

Information furnished by Exlar Corporation is believed to be accurate and reliable. However, no responsibility is assumed by Exlar Corporation for its use. Exlar reserves the right to change the design and operation of the equipment described herein and any associated motion products that may appear in this document. Information in this document pertaining to equipment not furnished by Exlar should be confirmed by that equipment manufacturer. Exlar assumes no responsibility for changes to information by other manufacturers or errors in that information or the description of that information. Information in this document is subject to change without notice.

CONTENTS

1.0 INTRODUCTION	3	4.16 Absolute Feedback	23
1.1 General Product Description	3	4.17 Battery Life Information.....	23
1.2 Product Features.....	3	4.17.1 Low Battery Voltage.....	23
1.3 Safety Considerations	5	4.17.2 Replacing the Battery	24
2.0 SYSTEM CONFIGURATION	6	4.18 Ethernet Options, EIP, TCP or ProfiNet IO	24
2.1 TTX Series Actuator.....	6	4.19 Shielded or Unshielded Cables	24
2.2 Options	6	5.0 MAIN POWER SUPPLY SELECTION.....	25
2.2.1 Internal Holding Brake.....	6	5.1 Unregulated AC/DC Power Supplies	25
2.2.2 Anti-Rotation Assembly.....	6	5.2 Regulated AC/DC Power Supplies	25
2.2.3 External Limit Switch	6	5.3 Power and Battery Systems	26
3.0 MECHANICAL INSTALLATION	6	5.4 Handling Regen Energy-Internal Shunt.....	26
3.1 Mounting Configurations.....	6	5.5 Handling Regen Energy-External Shunt.....	27
3.2 Mounting Considerations	8	5.6 Logic Power Supply	27
3.2.1 General Operation.....	8	5.7 Power Supply Wiring Diagrams	27
3.2.2 Actuator Alignment	8	5.8 Grounding	28
3.2.3 Anti-Rotation Assembly	9	5.9 Power Supply Connections.....	28
3.2.4 External Limit Switches	10	6.0 STARTUP	29
3.3 Lubrication.....	11	6.1 Considerations for Startup.....	29
3.4 Outdoor and Wash Down Installations	11	6.1.1 Safety Considerations	29
4.0 ELECTRICAL INSTALLATION.....	12	6.1.2 Rotary-to-Linear Motion Relationship	29
4.1 Introduction	12	6.2 General Startup Procedure.....	29
4.2 Supplied Connectors	14	7.0 MAINTENANCE PROCEDURES	30
4.3 Grounding (PE) Connection.....	14	7.1 Lubrication	30
4.3.1 Shielding.....	14	7.2 Seal Maintenance.....	31
4.3.2 Other Grounding Considerations.....	15	7.3 Replacement Faceplate Assembly Kit	31
4.4 DC Input Power.....	15	8.0 TROUBLESHOOTING PROCEDURE	32
4.4.1 Input Power Ratings	15	9.0 CABLE ACCESSORIES	33
4.5 Over Temperature Protection.....	15	9.1 TTIOC-xxx I/O Cable	33
4.6 I/O Power Supply.....	15	9.2 CBL-TTIPC-SMI-xxx Power Cable	33
4.6.1 I/O Connector Wiring	16	9.3 TTICO-xxx Communications Cable	34
4.7 Digital Inputs	18	10.0 PRODUCT RETURNS	35
4.8 Digital Outputs	18	11.0 CERTIFICATIONS	35
4.9 Actuator Brake Option.....	19	12.0 WARRANTY AND LIMITATION OF LIABILITY	36
4.10 Analog Input.....	19		
4.11 Analog Output	20		
4.12 Communications	20		
4.13 IA4 Option Board Connections	21		
4.14 4-20 mA Input	22		
4.14.1 4-20 mA Input Connection.....	22		
4.15 4-20 mA Output.....	22		

1.0 INTRODUCTION

1.1 GENERAL PRODUCT DESCRIPTION

The TTX Series is Exlar's latest family of fully integrated linear actuators. They feature a robust planetary roller screw mechanism integrated into the rotor of a brushless servomotor and drive. This unique design combines the high speed and high load capacity of the roller screw with the high torque-to-volume ratio of the brushless servomotor. This manual applies only to the 80 mm frame size with 48 Vdc input power. Other manuals will cover the 60 mm frame size - 48 Vdc powered actuators and the 240 Vac powered actuators. All of the required power components and the motion processor are contained in

the actuator housing. Software configuration and set-up uses the Exlar Expert software tools used on all Tritex II and TTX integrated actuators

Actuator Mechanical Specifications and Ratings

Please refer to the TTX section of the 2018 Standard Product Catalog for mechanical specifications and output force ratings. The catalog also contains available model options and ordering information for specific model selection.

TTX Series actuators feature an Ingress Protection Rating of IP65S.

1.2 PRODUCT FEATURES

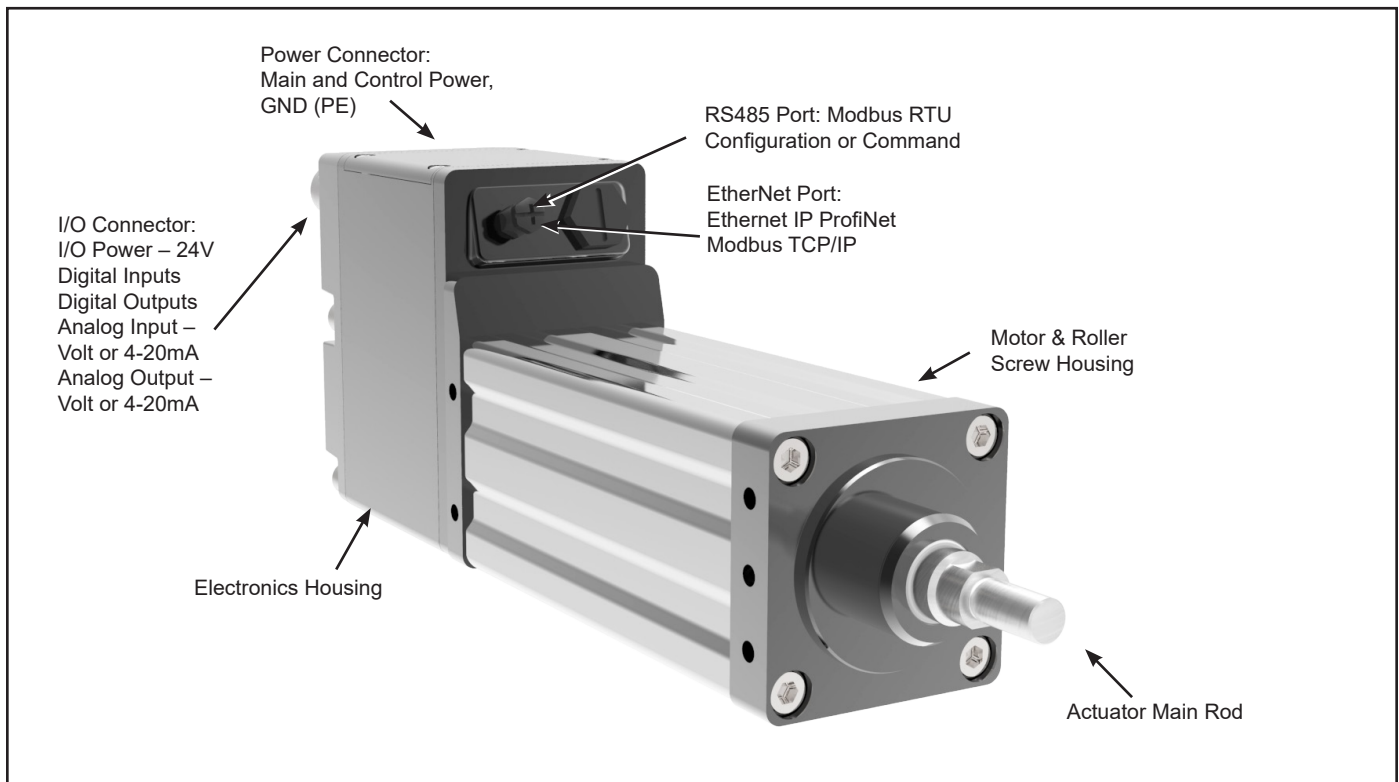

Figure 1 – TTX Series Actuator features

DRIVE SPECIFICATIONS FOR ALL TTX080 240 VOLT MODELS

Drive Specifications	
Main Power Input Voltage Control and Power Input Voltage (Optional)	Nominal Input Voltage: 12 to 48 Vdc Tolerance: +/-10% of nominal Note: Control Power is optional.
Optional External I/O Power Supply (Required with brake)	24 V dc +/- 10% - 0.8 A dc max load Provides power for Digital Outputs when powering brake and 12 to 30V when no brake is used Requires Class 2 source, or protected by 3A maximum fuse
Digital Inputs	10 to 30 Vdc for ON state 0 to 1 Vdc or 0 to 1mA for OFF state Common return at "I/O Common" terminal Programmable functions. Number of channels varies by I/O option: 4 for 4-20ma and 8 for all others
Digital Outputs	Powered at I/O +24V terminal 1V maximum drop from supply voltage 100 mA continuous load per channel Short circuit and overload protected Programmable functions Number of channels varies by I/O option: 3 for 4-20ma and 4 for all others
Analog Input (Not available on 4-20mA I/O option)	0-10 Volts or +/- 10 Volts differential input 13 bit resolution, ± 0.2% accuracy. Programmable function – Position, Velocity, or Torque
Analog Output (Not available on 4-20mA option)	0-10 Volts at up to 10 mA 11 bit resolution; ± 0.5% accuracy Programmable function
4-20 mA Analog Input (4-20mA I/O option only)	Externally powered, fully isolated 11.5V max lift-off at 20mA 14 bit resolution , ± 0.1% of span accuracy Programmable function – Position, Velocity, or Torque
4-20 ma Analog Output (4-20mA I/O option only)	Externally powered, fully isolated 12V max lift-off at 20mA 12 bit resolution, ± 0.2% accuracy
Serial Interface	Optically isolated RS-485, Modbus RTU protocol Selectable bit rate: 38.4kbaud max
Commutation	Sinusoidal, 10kHz PWM, space vector voltage
Position Feedback	Resolution: 0.001 revolution Accuracy: + / - 0.002 revolution Multi-turn absolute position is standard, but may be disabled and battery back-up removed
Enclosure Rating	IP65S with plugs, caps, and cover properly installed and connectors or wiring ports properly sealed
Environmental	Operating temperature range: 0° to 65° C Derate continuous current 1 % per °C above 25° C Storage Temperature: -40°C to 85°C Operational Altitude: up to 3000 meters Long-term vibration: 1g rms 5 to 500 Hz Occasional vibration: 2.5g rms 5 to 500 Hz. Shock: 5g peak

1.3 SAFETY CONSIDERATIONS

Safety is of paramount importance during the installation and operation of your TTX Series actuator. Throughout this manual, content flagged with the cautionary symbols shown below should be read carefully by installers and operators to help avoid property damage, personal injury or death.



WARNING! Indicates a potentially hazardous situation which could result in serious injury or death if precautions are not



CAUTION! Indicates the information following is necessary for avoiding a risk of damage to the product or other equipment.

IMPORTANT Identifies statements that provide important information to help ensure safe and trouble-free installation and operation.

Several general warnings and cautions follow. In addition, refer to the AGENCY APPROVALS section for Conditions of Use for additional limits and requirements to ensure safe installation and operation.



WARNING! General

Failure to follow safe installation guidelines can cause death or serious injury. Voltages and currents in the product can cause electric shock or burns and could be lethal. Extreme care is necessary at all times when working with or adjacent to the product. The installation must comply with all relevant safety legislation in the country of use. The forces created by the actuator could be lethal or cause severe injury if proper protection is not provided to keep personnel away from moving components.



WARNING! System Design and safety for personnel
The actuator is intended as a component for professional incorporation into complete equipment or a system. If installed incorrectly, the actuator may present a safety hazard. The actuator uses high voltages and currents, carries a high level of stored electrical energy, and is used to control equipment which can cause injury. Close attention is required to the electrical installation and the system design to avoid hazards either in normal operation or in the event of equipment malfunction. System design, installation, commissioning and maintenance must be carried out by personnel who have the necessary training and experience. They must read this safety information and this manual carefully.

None of the functions or features of the TTX actuator may be used to ensure safety of personnel. They must not be used for safety-related functions.

For example the actuators enable / disable, brake, stop/ start and forward/reverse functions are not sufficient for use in safety-critical applications without additional independent channels of protection. Careful consideration must be given to the functions of the actuator, which might result in a hazard, either through their intended behavior or through incorrect operation due to a fault. In any application where a malfunction of the actuator or its control system could lead to or allow damage, loss or injury, a risk analysis must be carried out, and where necessary, further measures taken to reduce the risk- for example a fail safe brake in case of loss of actuator braking power.



WARNING! Hot Surface – Risk of Burn

Exposed surfaces of the actuator may exceed 70°C under normal operation and can take a long time to cool, resulting in a risk of burns when touched.

2.0 SYSTEM CONFIGURATION

2.1 TTX SERIES ACTUATOR

TTX Series actuators provide a robust solution for long-life, continuous-duty applications even when environmental contaminants are an issue. In most rotary-to-linear devices, critical mechanisms are exposed to the environment and must be frequently inspected, cleaned and lubricated. In contrast, TTX Series actuators are designed with all converting components mounted within sealed motor housings. With a simple bushing and seal on the smooth extending rod, abrasive particles or other contaminants are prevented from reaching the actuator's critical mechanisms. As a result, actuator life can exceed that of a ball screw actuator by 15 times, even in high-speed, high-force applications. In addition, the TTX Series has an on-board amplifier with control software and firmware available from Exlar.

2.2 OPTIONS

2.2.1 Internal Holding Brake

Many applications require the addition of a holding brake. The Exlar internal holding brake is engaged by a permanent-magnet. The mechanical advantage of the roller screw allows the holding brake to prevent the output rod from back-driving the load. The holding capacity of the brake is sufficient to hold the rated force of the actuator.

2.2.2 Anti-Rotation Assembly

The unique design of TTX Series actuators helps simplify actuator setup by allowing the user to rotate the extending rod and thread it in and out of the actuator for mechanical attachment or system testing. In most applications, the load is coupled to linear bearings or some other support device, preventing rotation during operation. To ensure proper linear motion in applications in which the rod is free to rotate, an Anti-Rotate Assembly is required to prevent the rod from rotating.

2.2.3 External Limit Switch

A TTX Series actuator equipped with the anti-rotate and limit switch options can accommodate multiple limit switches for use as end-of-travel limit switches or home position sensors positioned outside the low-profile extruded channel housing.

3.0 MECHANICAL INSTALLATION

3.1 MOUNTING CONFIGURATIONS

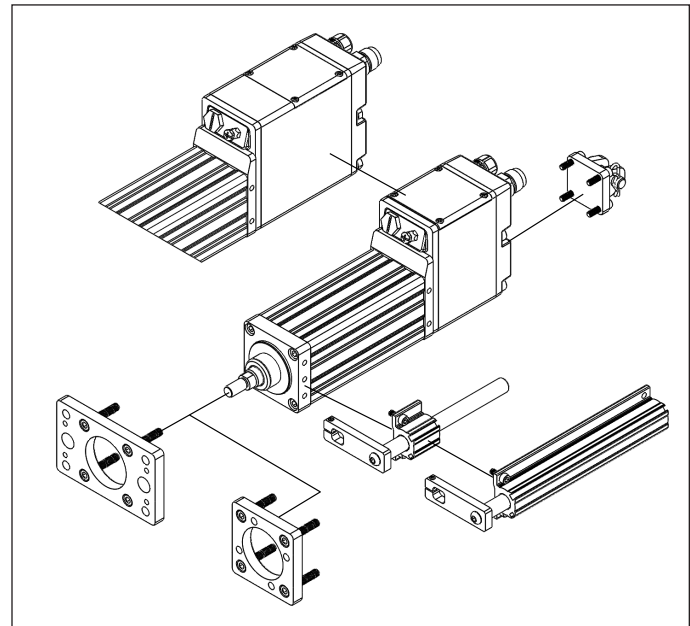

Figure 2 – Mounting configurations

TTX Series actuators mounting configurations:

- Rear clevis
- Front flange
- Tapped face
- Side mount.

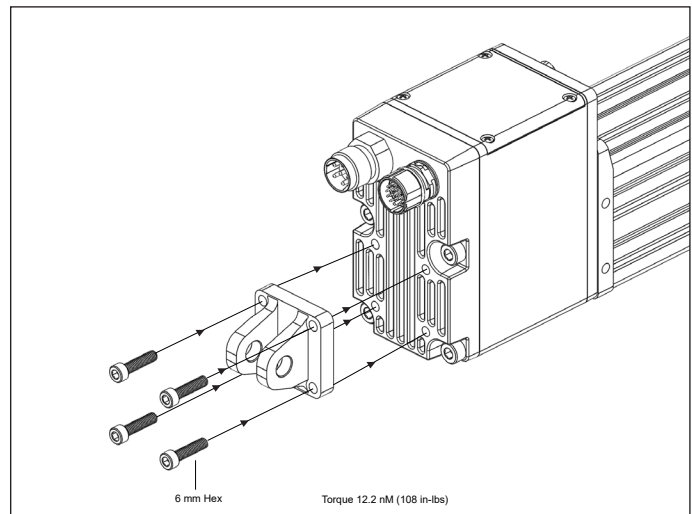

Figure 3 – Rear clevis mount (**NOTE:** Dimension drawings can be found in the TTX Series Actuator catalog or on the Exlar website.)

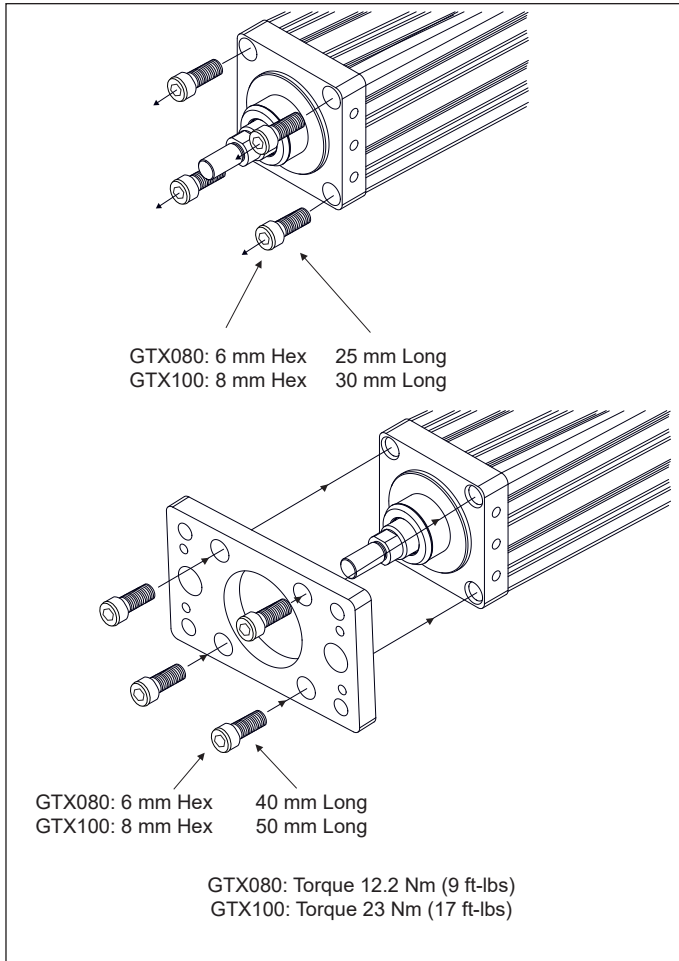

Figure 4 – Flange mount

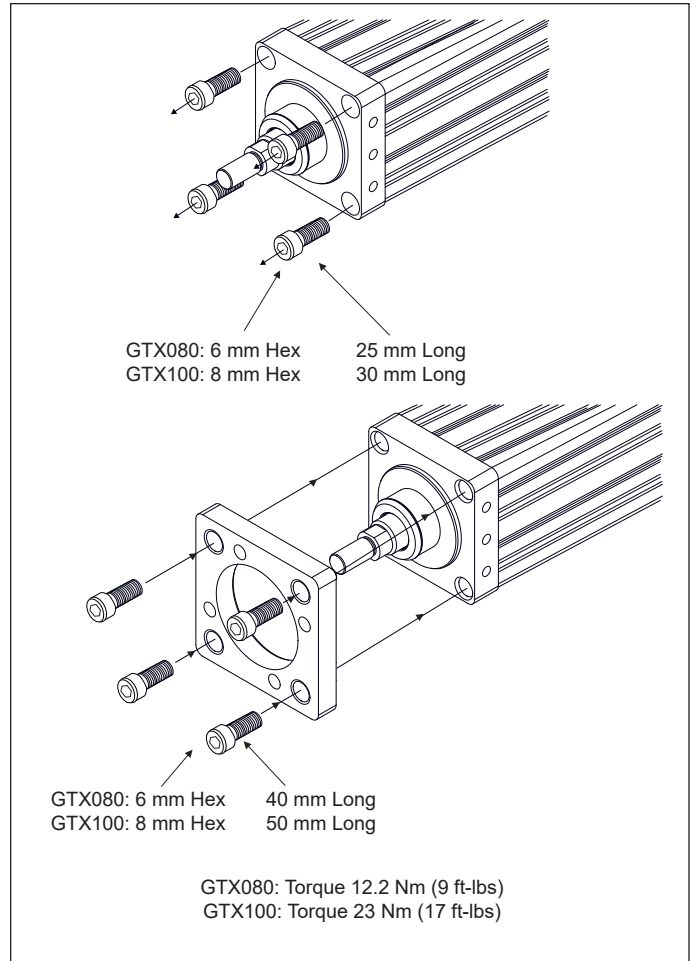

Figure 5 – Tapped face mount

3.2 MOUNTING CONSIDERATIONS

3.2.1 General Operation

The TTX linear actuators function in the same manner as a brushless servomotor. The servo amplifier is used to rotate the motor at controlled speed and torque, and for controlled numbers of revolutions and move times. This rotary motion is translated into linear motion by the internal planetary roller screw mechanism of the TTX Series linear actuator.

See sections 2.2.1, 2.2.2 and 2.2.3 regarding the holding brake, anti-rotate mechanisms, and external limit switches and that can affect the operation and motion of the actuator.

The relationship between the rotary motion of the motor and the linear motion of the actuator corresponds to the following relationships:

English

Linear Distance Traveled (in) = (Motor Revolutions)*
(Roller Screw Lead (in))

Linear Speed (in/sec) = ((Motor RPM) / 60)*
(Roller Screw Lead (in))

Linear Force (lbf) = ((Motor Torque (in-lbf))*(2π)*
(efficiency)) / (Roller Screw Lead (in))

Metric

Linear Distance Traveled (mm) = (Motor Revolutions)*
(Roller Screw Lead (mm))

Linear Speed (mm/sec) = ((Motor RPM) / 60)*
(Roller Screw Lead (mm))

Linear Force (N) = ((Motor Torque (N-m))*(2π)*
(efficiency)) / (Roller Screw Lead (mm))

All of the above relationships require proper anti-rotation of the TTX actuator rod. For more information on sizing and selection of TTX actuator and servo amplifiers to power them, consult the sizing and selection section of the Exlar catalog.



CAUTION! Care should be taken not to exceed the physical travel limits of TTX actuators. Doing so will cause the actuator to end-crash internally. End crashes can physically damage the roller screw and the internal components of the actuator. Care should be taken to avoid high-speed impact with objects of high rigidity that immediately stop the travel of the actuator with no deceleration or energy absorption. An example

would be a high-speed impact of two solid steel parts. The resulting impact will create a very short effective deceleration time. Kinetic energy contained in the rotating inertia of the actuator and motor can possibly generate extremely high impact forces that exceed the mechanical capacities of the actuator and cause physical damage to the actuator. For applications requiring this type of impact, contact Exlar application engineering to insure that the actuator is properly sized or provisions are made to absorb the induced energy.

3.2.2 Actuator Alignment

IMPORTANT! Aligning the TTX Series actuator with respect to the load it is moving is critical. Any misalignment will decrease the life of the actuator's components and may adversely affect application performance.



CAUTION! Excessive side load on the actuator output rod will dramatically reduce the life of the actuator and should be avoided. Side load can result from misalignment or loading that is not in line with the actuator output rod.

Side-mounting notes:

TTX Series actuators include threaded holes in the faceplate and endplate. Exlar recommends using hardened fasteners to mount an actuator to your machine frame with an engagement depth of two times the screw diameter for tapped holes.

Stroke length and centering must be carefully considered to avoid hitting physical travel limits in linear actuators, including over travel in fast motion profiles. Homing to end of travel may be done at very slow speed and limited force, but homing manually or to a limit switch, or maintaining continuous Logic Power or using the absolute position feedback option to avoid frequent homing should be considered. Apply appropriate deceleration ramps to end of moves, or velocity and acceleration limits in positioners to prevent over-travel.

IMPORTANT! Tighten four cap screws to 12.24 Nm (9.0 ft-lb) max. Failure to properly tighten the screws can affect normal operation, damage the actuator and/or cause possible premature actuator failure.

3.2.3 Anti-rotation Assembly

To keep the extending rod from rotating, Exlar offers the Anti-rotation Assembly shown below.

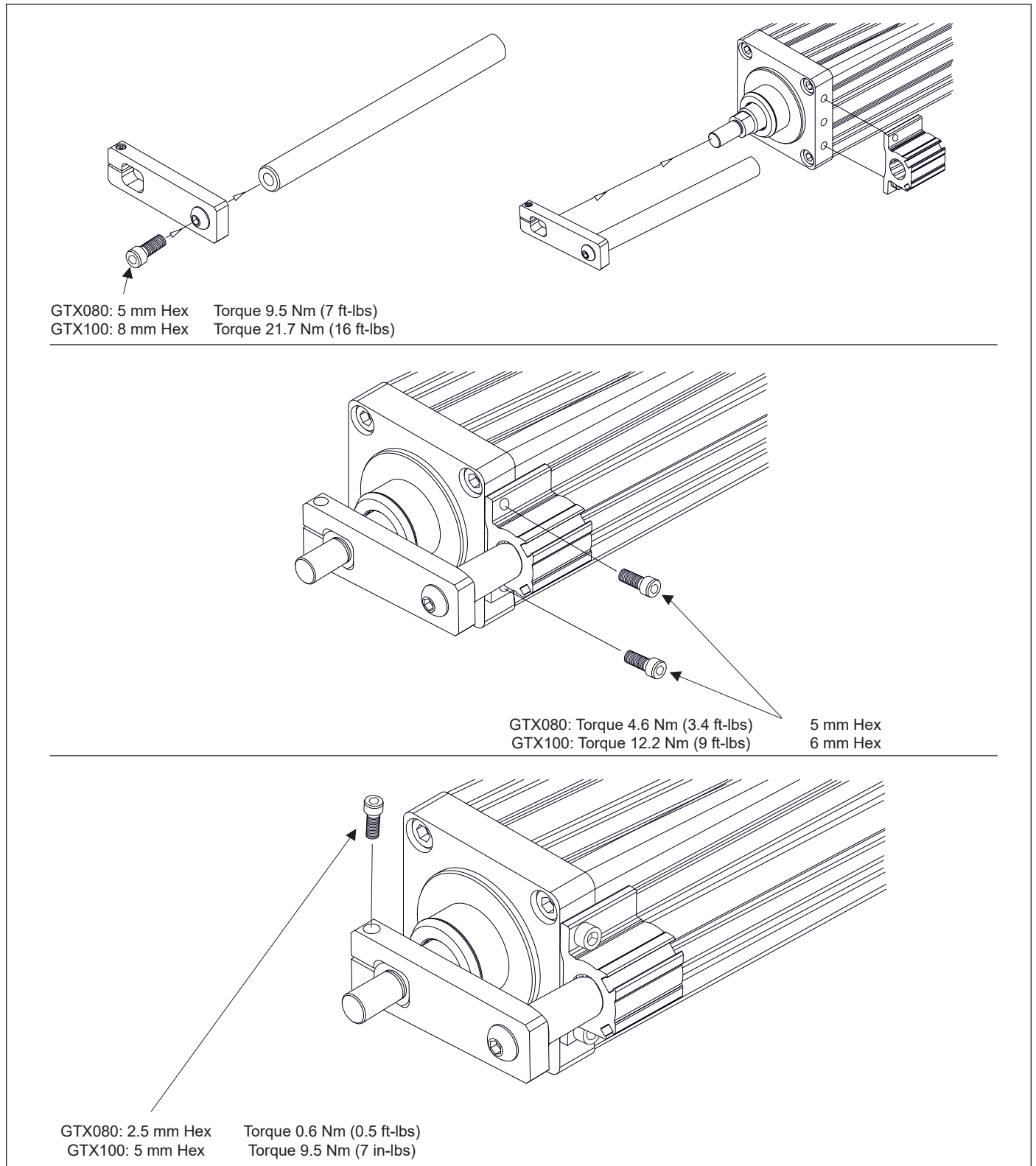

Figure 6 – Anti-rotation Assembly (shown in standard location)

3.2.4 External Limit Switches

This option allows multiple external switches (sold separately) to be externally mounted to the actuator. TTX actuators generally would not use more than one switch for a home marker. These adjustable switches provide travel indication to the controller. A bracket with inductive proximity switches mounts to the outside low-profile extrusion and senses a traveling magnet located inside the anti-rotate tube. This option also provides anti-rotation.

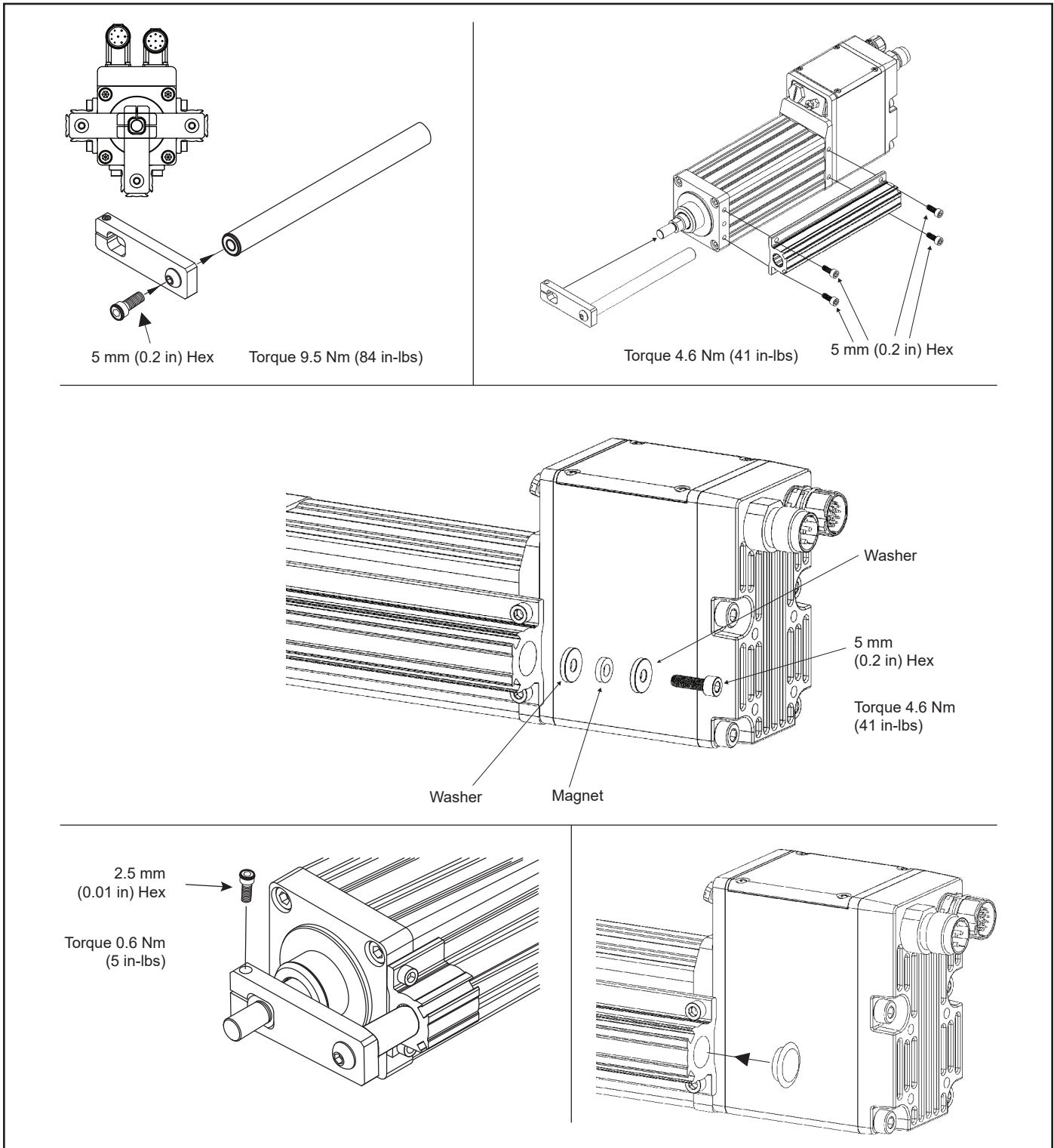

Figure 7 – Limit switch mounting

3.3 LUBRICATION

TTX linear actuators are shipped from the factory fully greased and ready for installation. Exlar uses Mobil SHC 220, a high performance, extreme-pressure grease. The unique physical properties of the synthetic base oil provide outstanding protection against wear, rust, corrosion, and high or low-temperature degradation. See section 6.1 for more information on lubrication.

3.4 OUTDOOR AND WASH DOWN INSTALLATIONS



CAUTION! Liquid ingress damages TTX electronics. Damage due to water or other liquids can be very extensive, may not show up immediately, and is not generally covered under warranty.

TTX ingress ratings: IP65S . TTX actuators are not intended for applications where the actuator could possibly be submerged. Liquid ingress causes serious damage to electronics over time. A frequent and often overlooked entry point is through conduit or wireways. When new, the seals are effective to IP65S or better. However, over time, and depending on the amount of side load, seals can wear and eventually allow moisture in. Contact Exlar application engineering for special options. Here are some additional recommendations to prevent liquid entry:

1. Avoid installations with main rod or shaft facing up if possible . Otherwise make external provisions to keep water away from the main rod or shaft.
2. When using the power and I/O connectors verify the cable end connectors can seal properly and have the desired IP rating. Be sure to screw the plug all the way on to the receptacle for proper sealing.
3. Position conduit fittings or create a drip loop in cable or flexible conduit so water does not drain towards the conduit fitting as shown.
4. When the wire termination cover is re-installed, verify the gasket is in place and the surfaces of the gasket as well as the cover are free from debris so a good seal can be achieved.
5. When re-installing the termination cover install all four screws to within about one turn from contact, then hold the cover flat in position and bring all screws to seat. Then tighten the screws to about 7 lbf-in (0,8 Nt-m).
6. The TTX actuator has conduit hole plugs to cover unused conduit entries, verify they are all in place and fully seated.

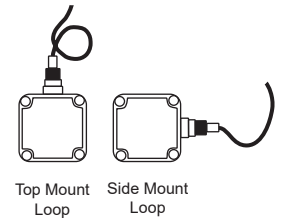

4.0 ELECTRICAL INSTALLATION

4.1 INTRODUCTION

All of the required power components, motion processor, I/O, and communications ports are contained in the actuator housing. TTX DC models do not have an internal 24 VDC power supply. External I/O Power is required for digital outputs and brake. SRC +24 terminals are present on termination board but make no internal connection.

The following diagrams show the electrical connections schematically:

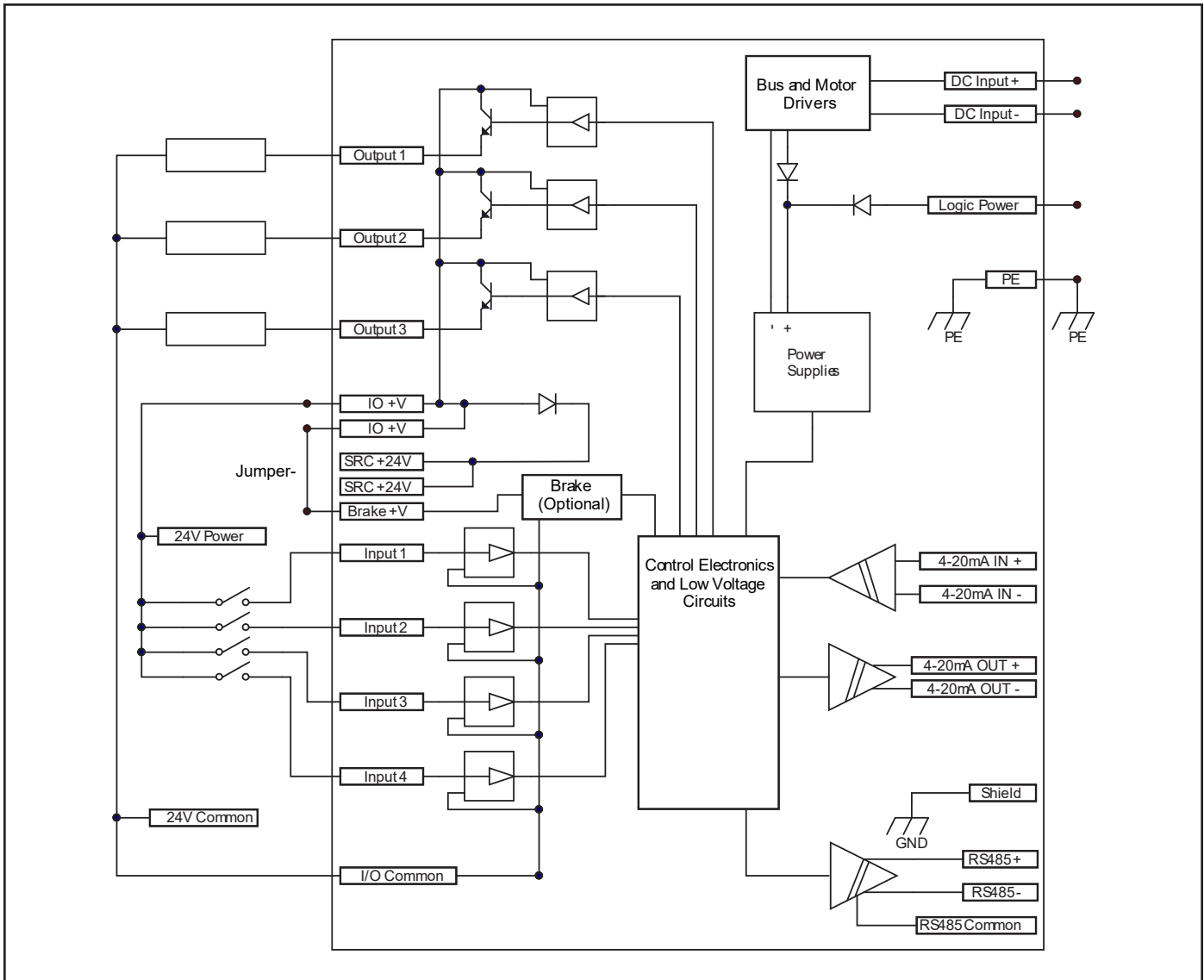

Figure 8 – Electrical Diagram 4-20 mA

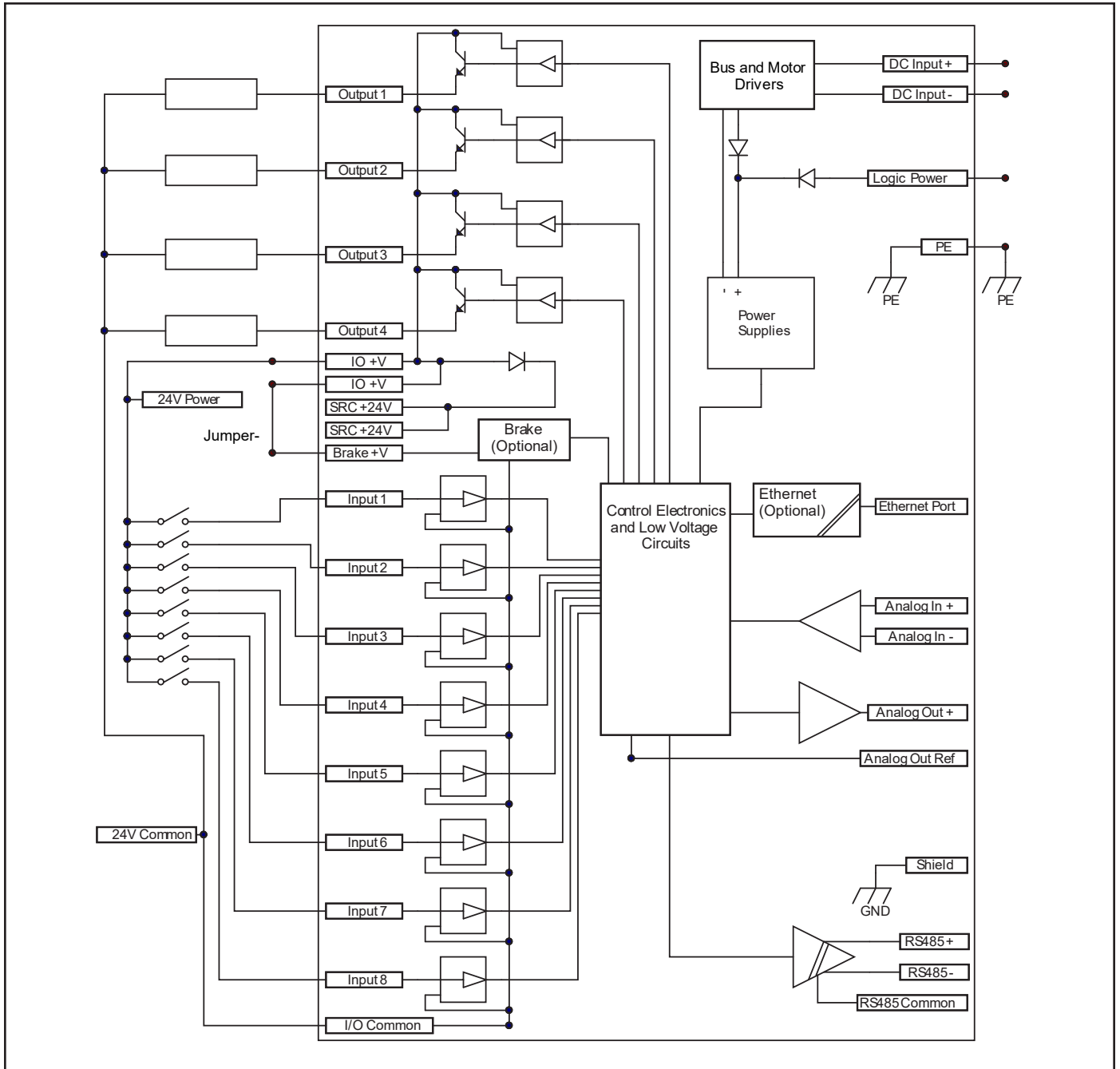

Figure 9 – Electrical Diagram STD I/O

4.2 SUPPLIED CONNECTORS

All standard models have connectors for external electrical interface, though the connectors may be removed as needed for direct wiring to internal terminals or connections.

The connectors are installed in M20x1.5 threaded holes machined into the rear electronics housing and can be used as cable entry ports. The power connector is installed in the right rear port and contains main (motor) power connections. The I/O connector is installed in the left rear port. The user may remove or relocate the connectors as needed as long as any unused holes are properly capped to prevent water or dust intrusion. Adapters for 1/2 inch NPT thread or cable glands may be used but are not furnished.

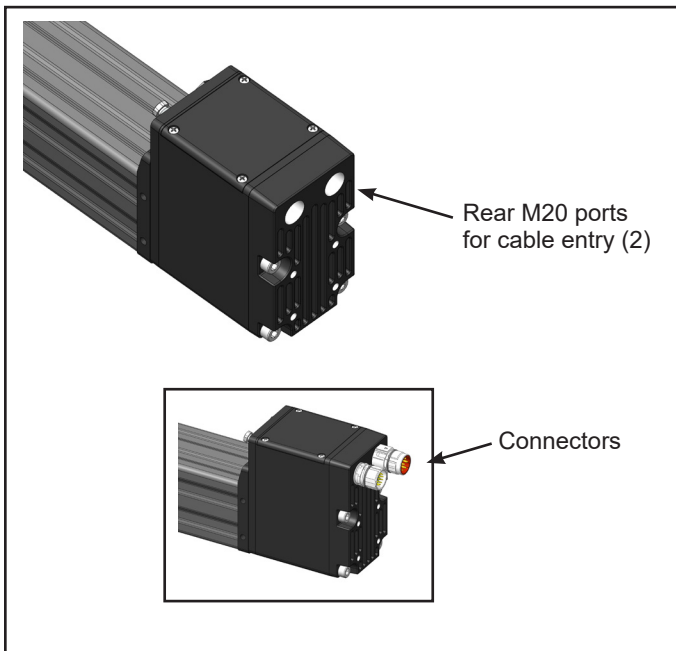

Figure 10 – M20 Cable Entry Ports

A PG 9 threaded hole is machined at the front of the electronic enclosure. This hole has a connector installed for Ethernet based communications options: ProfiNet, Ethernet-IP, or Modbus TCP. Otherwise the hole is plugged but available for alternate use.

All models have a connector for RS-485 communications at the front of the electronics enclosure most often used for temporary connection to the Expert software configuration tool, but also used for connection to a Modbus RTU host.

The enclosure cover may be removed for access to I/O and power terminals and some wiring option jumpers. Removing the cover also provides access to a battery for multi-turn absolute feedback. Always replace the cover immediately to prevent accidental entry of water, wire trimmings, or metal cuttings from nearby drilling or cutting operations during installation. See wiring section below.

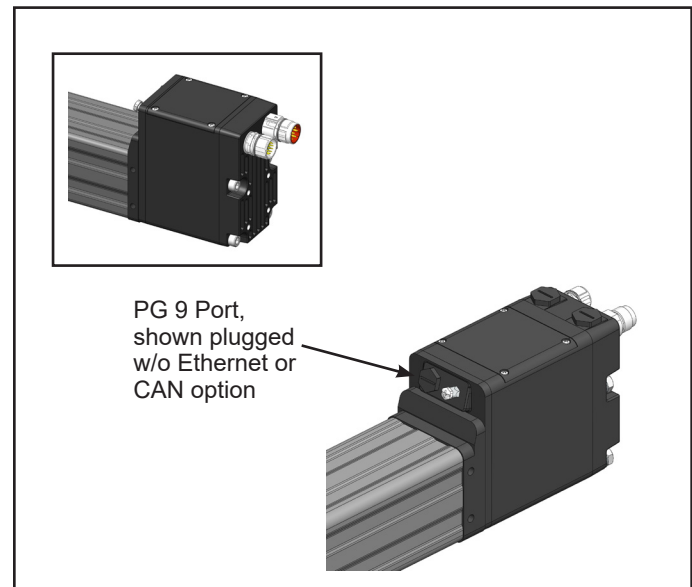

Figure 11 – PG9 Cable Entry Port / Communication Connector

4.3 GROUNDING (PE) CONNECTION

There is a PE terminal on the internal power terminal block. This terminal must be used to ground the actuator case.

4.3.1 Shielding

In order to meet the European EMC Directive for an installation to provide immunity from radio frequency (RF) interference and to minimize RF emissions, the power and I/O wiring or cables must be shielded. Metallic conduit (solid or flexible) can serve as a shield. Shields must be connected to the enclosure at the entry / exit point.

The connectors and cables supplied by Curtiss-Wright properly terminate shields. If cable glands are used, make sure the cable gland has a feature to make contact between the metal

body and shield and that the outer jacket is removed as recommended by gland manufacturer and installed according to manufacturer instructions. Example shown in diagram below. A shield connection such as the one shown does not qualify as a PE connection.



CAUTION! Avoid Loose Conductive Material

Always apply tape or heat shrink to the end of the shield to prevent strands of the braided shield from breaking off and shorting internal electronics or compromising spacing.

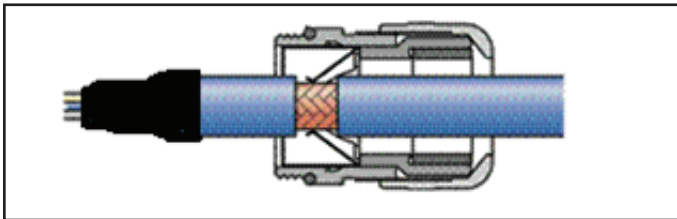

Figure 12 – Example of a shielding type cable gland.

An Ethernet cable is not required to be shielded, or if shielded, does not require that the shield is connected at the actuator end. Do not use a shielded RJ45 jack for an internal connection to this actuator.

4.3.2 Other Grounding Considerations

Extra-low voltage DC power supplies for I/O circuits or a holding brake must be ground referenced on the negative side to prevent stacking voltages where there is more than one source. Avoid use of independent “Instrument Ground” connections. All ground connections must run back to a single point.

It is recommended that driven parts are connected to stationary parts of the machine with grounding jumpers. Some applications produce static electric charges in the moving parts of a machine, for example plastic molding, that produce static charges or impulses that exceed those in EMC tests.

4.4 DC INPUT POWER

4.4.1 Input Power Ratings

The following table shows rated input voltage and current. The maximum voltage applied to the TTX080 terminals must not exceed 53 Vdc from Bust to Common and Common must be tied to PE near or at the power source. Operation on less than rated voltage results in proportionally reduced maximum speed. Refer to Torque/Speed diagrams in catalog for additional information.

Actuator Size	Input Voltage (Volts DC)	Rated Continuous Input Current (Amps)
80 mm	12 to 48 ± 10%	18.0

4.5 OVER TEMPERATURE PROTECTION

UL/CSA approved motor over temperature sensing is not provided by the actuator. Motor over temperature protection relies on limiting maximum current to the motor and if time-averaged motor current exceeds a continuous current setting, the actuator trips or faults and disables the drive indicating a Continuous Current fault. The continuous current fault level is set at the factory and cannot be adjusted. These limits are set to keep the stator below 130°C while in a stall condition at 40°C ambient.

The motor contains a temperature sensor embedded in the stator windings to provide an actual temperature indication. The actuator trips or faults when the temperature reaches 130°C and disables the drive indicating an Actuator Over-temperature fault.

Additional over temperature protection is provided by a sensor in the drive electronics which generates a fault when the board reaches 110°C.

Though some fault conditions may be configured to take action other than to disable the actuator immediately, reconfiguration of these two faults is not allowed in order to protect the actuator motor and electronics.

4.6 I/O POWER SUPPLY

An external I/O Power Supply must be used to provide power for digital inputs, digital outputs, and the optional holding brake, if present. On DC models of TTX actuators, logic power is not associated with I/O power and there is no internal 24V supply from main DC (motor) power, making them significantly different from AC powered models. The I/O power supply must have the negative side connected to ground and the positive side fused at 2A unless internally limited to 3A or less. The I/O power supply is typically 24 Vdc nominal, but other nominal voltages are possible in some cases. Digital I/O and brake circuits as a group are optically isolated from main power circuits to provide some fault isolation and enhance immunity from transients and electromagnetic interference.

All standard models have a 19 pin M23 connector for I/O and I/O power connections are positive to pin 6 and 0 V return to pin 19. Though the connection at pin 19 ultimately goes to the negative terminal of the external power supply, it is required to be ground referenced so is described as 0 V or “I/O Common” and labelled “IOCom” internally. All digital inputs are powered externally but have a single return through I/O Common. The connection at pin 6 is described as “IO +24V” and labelled “IO+V” internally. If the brake option is present, the voltage must be 24V +/- 10%. If no brake is present, the voltage applied at I/O +24V may vary considerably as long as the loads connected to digital outputs are compatible with the I/O power supply voltage. 24V I/O systems are most common, but 12V systems are supported. If no brake is present and no digital outputs are used, no connection to IO +24V is required at all.

TTX080 models have a cover that may be removed to access the Termination Board with push-button release spring terminals for connections. Connections could be modified if needed, or the I/O connector could be removed entirely for direct wiring using other wiring methods through the M20 threaded port. Details of alternate wiring are not addressed in this manual at this time as they would be engineered by the user for a specific application. The same Termination Board is used on both AC and DC models and with no internal power supply, the “Src+24” terminals are not used on DC models. A factory installed jumper will tie the two “Src+24” terminals to prevent accidental connections to these terminals. On models with brakes, there is also a jumper from one “IO+V” terminal to the “Brk+V” terminal to power the brake from the I/O Power Supply.

I/O Power Supply Wiring and Fusing

Volts	Amps	Fuse	Wire
24 Vdc +/- 10%.	1	2 Amp, if power supply is not limited at 3 Amp or less	18 AWG (0.8mm ²)

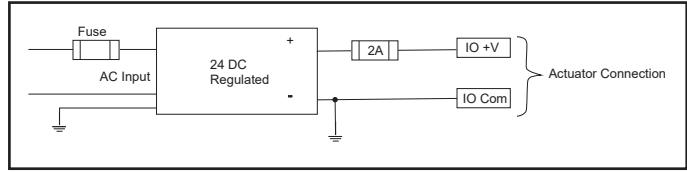

Figure 13 – Wiring for External I/O Power Supply

CAUTION! Make sure 24 Vdc power supplies are connected in the correct polarity. Some reversed connections will cause damage to the circuits. The I/O Common terminal must be connected to the negative and grounded side of the power supply. An external supply should not be connected directly to the +24V Source terminals.

4.6.1 I/O Connector Wiring

Standard M23 19 pin Connector Pin Assignment and Wire Color Code

FUNCTION	Connector Pins	Wire Color Code for Internal Wiring & TTIOC Cable
Digital Input 1	1	White/Yellow
Digital Input 2	2	White/Red
Digital Input 3	3	White/Green
Digital Input 4	4	White/Black
*Digital Input 5	5	Red/Black
IO +24V	6	Red
*Digital Input 6	7	Red/Green
*Digital Input 7	8	Red/Yellow
*Digital Input 8	9	Beige
*ANALOG IN+	10	Green
*ANALOG IN-	11	White
Shields	12	Gray (internal wire) or Clear (cable)
*Analog Out +	13	Blue
*Analog Ref	14	Orange
*Digital Output 4	15	White/Brown
Digital Output 3	16	White/Orange
Digital Output 2	17	White/Blue
Digital Output 1	18	Light Red (Pink)
IO Common	19	Black

* For the 4-20mA (-IA4) option:
Inputs 5, 6, 7 & 8 and Output 4 are not available.
The analog voltage input and output are replaced with 4-20 mA input and output respectively.

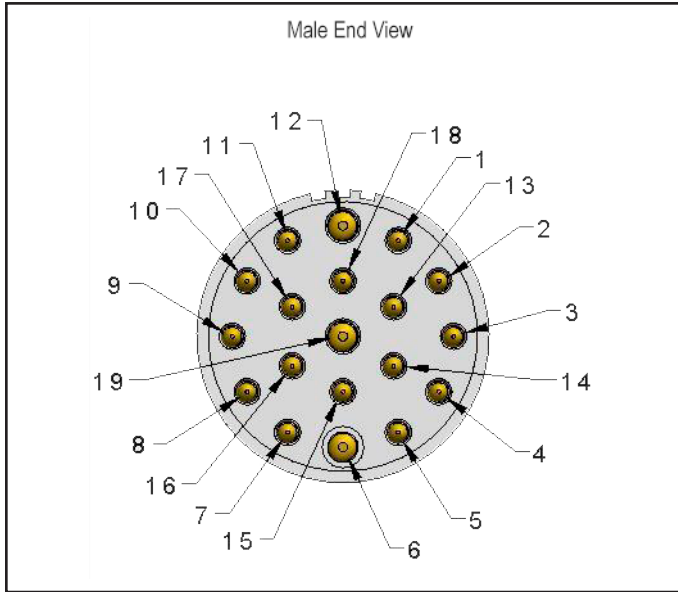

Figure 14 – Input /Output Standard M23 Connector Front View (19 pins)

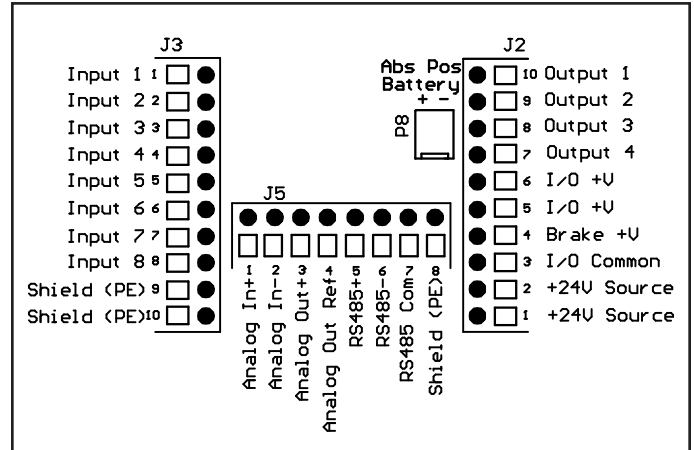

Figure 15 – SIO and Ethernet Option

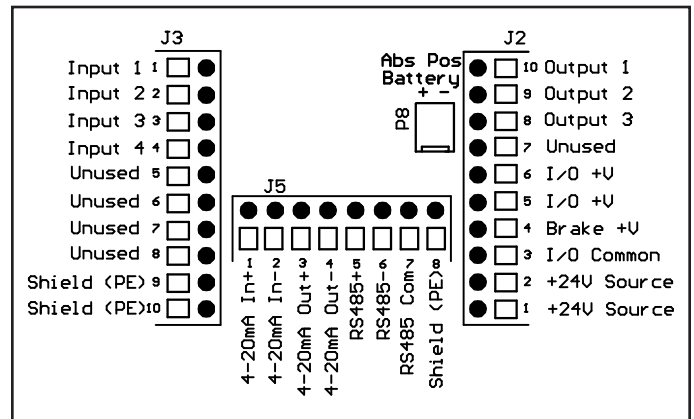

Figure 16 – IA4 Option

Internal Termination Board Terminal Assignments

J3 Pos #	Label	Function	J2 Pos #	Label	Function	J5 Pos #	Label	Function
1	In 1	Digital Input 1	1	Src+24	Not Used	1	*AI+	*Analog IN+
2	In 2	Digital Input 2	2	Src+24	Nor Used	2	*AI-	*Analog IN-
3	In 3	Digital Input 3	3	IOCom	I/O Common	3	*AO+	*Analog OUT
4	In 4	Digital Input 4	4	Brk+V	Brake +	4	*AO-	*Analog REF
5	*In 5	Digital Input 5	5	IO+V	I/O +V	5	RS485+	RS485+
6	*In 6	Digital Input 6	6	IO+V	I/O +V	6	RS485-	RS485-
7	*In 7	Digital Input 7	7	*Out 4	Digital Output 4	7	Com	RS485 COM
8	*In 8	Digital Input 8	8	Out 3	Digital Output 3	8	Shld	Shield (to PE)
9	Shld	Shield (to PE)	9	Out 2	Digital Output 2			
10	Shld	Shield (to PE)	10	Out 1	Digital Output 1			

* For the 4-20mA (-IA4) option:

Inputs 5, 6, 7 & 8 and Output 4 are not available.

The analog voltage input and output are replaced with 4-20 mA input and output respectively.

4.7 DIGITAL INPUTS

TTX digital inputs are single ended positive voltage inputs with negative side all to I/O Common. Standard I/O (-SIO in model) and Ethernet options have 8 inputs, and the 4-20mA I/O (-IA4 in model) have 4 inputs. Since they require a positive voltage to turn on, they are directly compatible with sourcing outputs only. The voltage for each input can be sourced from any supply with the negative side tied to I/O Common. Typically this is an external 24 V supply used for digital outputs. Each input can be assigned to any of the internal input functions using Expert software. It is important that the external power source common is connected to PE.

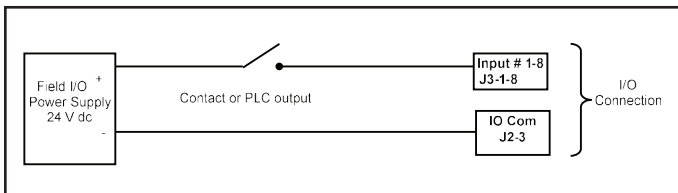

Figure 17 – Input Wiring with External 24Vdc Power Supply

Digital Input Specifications

Description	Specification
Absolute Max Input Voltage*	-10-40 Vdc to I/O Common
Operating Input Voltage Range	0-30 Vdc to I/O Common
On state voltage range	10 – 30 V dc
Off state voltage range	0 – 1 V dc
On state current 10V (min) 24V (nominal) 30V (maximum)	3.3 mA 5.0 mA 5.7 mA
Effective Load Resistance (24V)	4.8 kΩ
Off state current (max)	1.0 mA
Update rate	1 ms (typical)

* Inputs are protected from switching transients. Sustained voltage outside the Absolute Max range may damage the circuit.

4.8 DIGITAL OUTPUTS

TTX digital outputs are the sourcing type with power from the I/O Power+ (“IO+V”) terminal. SIO and Standard I/O (-SIO in model) and Ethernet options have 4 outputs, and the 4-20mA I/O (-IA4 in model) have 3 outputs. The outputs have a weak pull-down resistor to I/O Common (“IOCom”) terminal just to prevent leakage current creating a floating voltage on an output. Typically power comes from an external 24 V supply used for digital I/O. It is important that the external power source common is connected to PE. Outputs have short circuit and thermal protection, and protection against inductive kick at turn-off. Each output can be assigned to any of the internal output functions using Expert software.



CAUTION! Each output is rated to continuously drive a 100 mA load and is short protected at 500 mA with automatic reset after the short fault is removed.

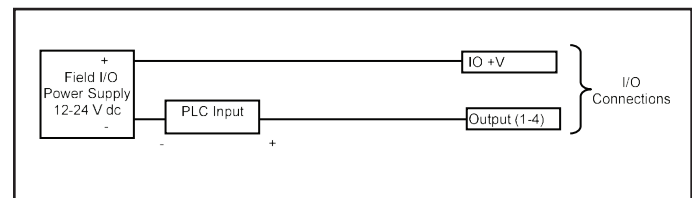

Figure 18 – Wiring of Outputs with External 24V Supply for Connection to PLC or Any Load

Digital Output Specifications

Description	Specification
Absolute Max Voltage	-50 Vdc to 0 V measured to I/O Power +
Operating voltage range for I/O Power +	12 to 30 Vdc to I/O Common (24V ±10% with brake)
On state maximum continuous current	100 mA
On state voltage drop (@ 50 mA)	.5 V typical
Short circuit protection (auto reset)	.5 A
Update rate	1 mSec

* Outputs are protected from switching transients, including kick from ordinary inductive loads. Sustained voltage outside the Absolute Max range may damage the circuits. Note that an output should not be driven more positive than I/O Power +.

4.9 ACTUATOR BRAKE OPTION

The actuators may be ordered with a brake option. This brake is intended as a “parking brake” and must not be used as a “stopping brake” while the actuator is in motion in any normal operation. Brake operation is controlled by internal logic signals, so power for the brake is normally applied at all times and the actuator engages and dis-engages the brake. The brake engages when brake voltage is removed. Brake voltage is 24 V +/- 10%. Since “Brk+V” and “I/O+V” terminals are jumpered in standard connectorized actuators, use of a brake places an additional voltage range limitation and increased load on the I/O supply. Brake current returns through IO common.

The brake can be released without main AC power applied as long as an external 24 Vdc supply is connected to I/O Power + and logic power is applied. It is not possible to directly release the brake unless the actuator controls are running so it is able to respond to a command to release the brake through I/O or communications.

It is worth providing details of internal brake control and how that affects motion. 24V is applied to Brake + continuously. Starting from a disabled status with brake engaged, when the actuator receives an Enable signal, it enables with a 0 velocity command which holds the motor position and applies voltage to the brake. A 0.1 sec time delay occurs before starting any motion to make sure the brake is fully released. Starting from the enabled state with the brake released or when the drive is disabled for any reason the drive will immediately apply full current to decelerate a moving motor to bring it to an abrupt stop and remove power to the brake. Then after a .1 sec delay to allow the brake to engage, the drive will be disabled. The brake can be released with the actuator disabled by turning on the Brake Override Input function. See the I/O Assignment section of the Expert Software Manual.



WARNING! If the brake is released using the Brake Override function and AC power is off or the drive is not enabled the load will be free. This may be dangerous in some applications.

On TTX080 models, other modifications to standard wiring can provide other functionality. If a separate interlock is required to ensure that power is removed from the brake while maintaining logic and I/O power, the jumper from “Brk+V” to “I/O+V” may be removed and a pin in the I/O Connector may be re-purposed for this.

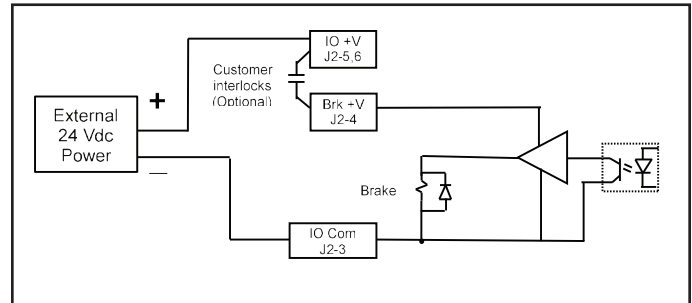

Figure 19 – Brake Connections with External 24V Power Supply

4.10 ANALOG INPUT

An analog input is provided for use as a position, velocity or current command. It can also be used for a Velocity Override feature to dynamically moderate velocity during a move. With the 4-20mA option, the voltage input channel described here is replaced with a 4-20mA channel described in a different section.

The analog signal must be wired differentially with a return wire to the analog signal reference for best noise rejection. Differential input range is -10 V to +10 V. It is not isolated from DC Input (main power), but has a common mode range of at least +/-5 V, meaning that the ground reference at the analog signal source and I/O Common at the actuator can vary by up to 5V positive or negative without affecting the received signal voltage.

The analog signal must be wired differentially with a return wire to the analog signal source for good noise rejection. An open circuit tends to 0 V, so it is recommended that a 0V signal produces zero command.

See Expert Software Manual for information on how to configure the analog input, analog motion, and related parameters.

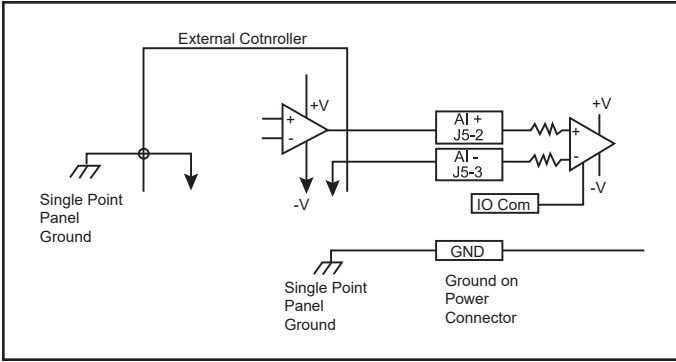

Figure 20 – Analog Input Wiring from External Controller

Analog Input Specifications

Description	Specification
Absolute Max Input Voltage *	+/- 40 Vdc to I/O Common
Differential Voltage Range	-10 V to +10 V
Analog In + Voltage Range	-15 V to +15 V
Analog In – Voltage Range	-15 V to +12 V
Input impedance	100 kΩ
Input resolution	13 bits over full -10 V to +10 V range
Update rate	0.5 ms

* Inputs are protected from switching transients. Sustained voltage outside the Absolute Max range may damage the circuit.

4.11 ANALOG OUTPUT

A 0-10 V analog output is provided. With the 4-20mA option, the voltage output channel described here is replaced with a 4-20mA channel described in a different section. The function of this output is programmable. It can be used for position, velocity or current monitoring, and can be dynamically switched between two sources.

The intent of this output is to provide a “monitor” type value not a “control” value, meaning the performance is not intended for the user to close a high speed position loop around this signal.

The analog output signal is a voltage from the Analog OUT terminal to the Analog REF terminal. The channel is not isolated and Analog OUT is at the same voltage as the DC Input (main power) terminal. The Analog Reference terminal should only be used when connected to an isolated input or a differential input. **DO NOT CONNECT TO A GROUNDED POINT EXTERNALLY!** A differential input should be used with this output to reduce interference from noise or differences in ground potential between opposite ends of the signals.

See Expert Software Manual for information on how to configure the analog output, analog motion, and related parameters.

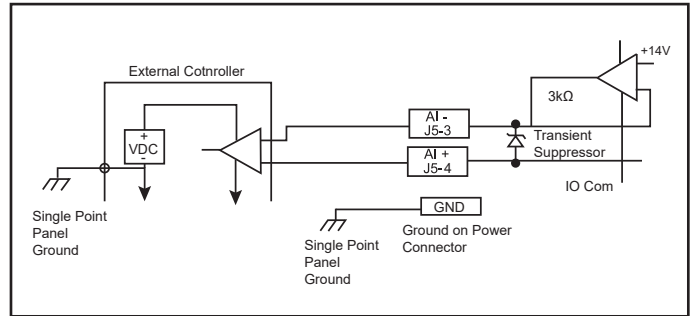

Figure 21 – Analog Output Wiring from External Controller

Analog Output Specifications

Description	Specification
Absolute Max Voltage *	-5 V to 15 V on Analog Out + +/- 5 V on Analog Ref
+/- 5 V on Analog Ref	0 - 10 V
Load Resistance	2 kΩ or higher
Output resolution	11 bits

* Circuits are protected from switching transients. Sustained voltage outside the Absolute Max range may damage the circuit. These signals are intended for connection only to higher impedance circuits.

4.12 COMMUNICATIONS

Serial communication to the actuator is provided through the 8 mm communication connector on the front of the actuator. The serial interface is two wire multi-drop RS485 and is optically isolated from all other circuits. The actuator supports Modbus RTU protocol for access to all drive parameters as described in the Tritex II Parameter Manual and Tritex Modbus Protocol Specification. Default settings for the port are: Baud Rate = 19.2k, Even Parity, Modbus device ID address = 1.

The following picture and table shows connector pin-outs. Refer to the Termination Board diagrams in the I/O Connector Wiring section for wiring to terminal block J5 under the access cover. Though in most cases only the 485+ and 485- signals are required, the 485 COM signal can enhance noise rejection if wired back to the master device signal common. The communications cable must be shielded with shield or shield drain wire connected to connector pin 2 or the connector body to meet EMC requirements.

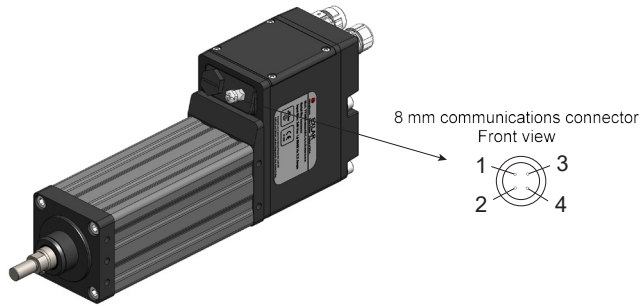

Function	8 mm Pin Number	Wire color for TTCOM	J5 Terminal #
485+	1	Brown	5
485-	3	Blue	6
485 COM	4	Black	7
Shield	2	Drain	8

When using the Expert software for set-up and diagnostics an RS485 converter will be required to interface between one of the PC communication ports and the RS485. This can be either a USB to 485 converter, such as the Exlar CBL-T2USB485-M8-xxx or any other standard 485 converter. See Accessories section.

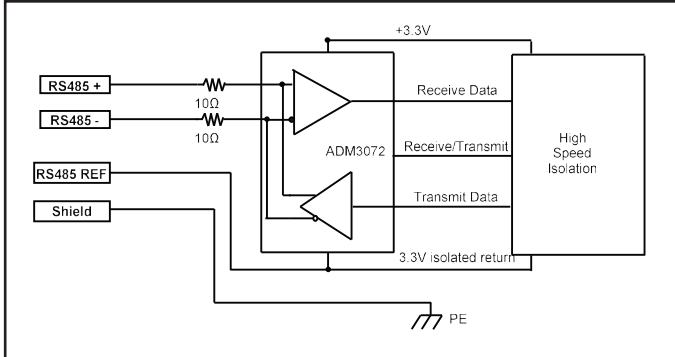

Figure 22 – Internal RS 485 Circuit

Modbus RTU is a multi-drop network, so multiple devices, some of which might not be TTX actuators, may be connected to a single Modbus Master. Devices on any single network need to have unique Modbus Device ID's before connecting them to the network. A recommended approach to avoiding multi-drop address collisions is that in normal operation no units have Modbus Device address 1 and any spares or additions at default address 1 so that a new or replacement unit can be added and then the address changed to the operational address. Since multiple masters are not supported, it may be more convenient to configure units using Expert software before final installation.

Because Modbus RTU at speeds supported on TTX cannot be considered a high performance link, data throughput and latency issues will generally limit the capabilities of Modbus RTU as a multi-drop network. Due to biasing resistors at each node and data throughput limitations, the maximum number of devices on a network should not exceed 8. A multi-drop network can be very useful for reporting status and changing parameters dynamically for different “recipes”, or for providing a single access point for Expert software connection.

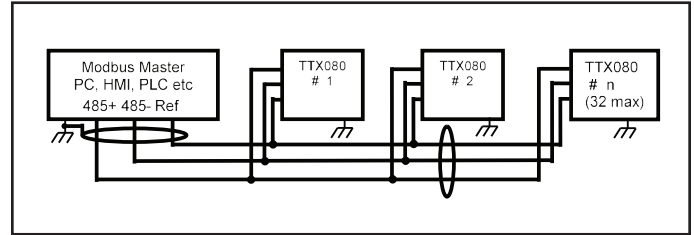

Figure 23 – Connecting multiple TTX actuators to a Modbus Master Host

In addition to the CBL-T2USB485-M8-xxx described above, the CBL-TTIOC-SMI-xxx cable assembly available in various lengths may be used to wire from the TTX080 connector to terminal blocks or screw terminal connectors. This cable is more suitable for permanent connection from one or more TTX actuators to other devices.

Cables supplied by Curtiss-Wright have the differential signal wires 485+ and 485-, the 0V reference for these signals 485 Com, and a shield. The 485 Com wire may not be needed but is recommended to reduce the effect of transients on signal quality. The 485+ and 485- signals should be a twisted pair, especially for long runs. Total RS485 cable length may be up to 100 m. Network topology is not important and termination resistors are generally not required.

4.13 IA4 OPTION BOARD CONNECTIONS

The IA4 4-20 mA I/O option board replaces the standard I/O board and provides one 4-20 mA isolated analog input and one 4-20 mA isolated analog output. These channels replace the standard Analog I/O input and output channels. The IA4 option board provides four isolated digital inputs and three isolated digital outputs, which is a reduction from the eight inputs and four outputs available on the standard I/O board. Due to space limitations, Ethernet based communications are not supported with the IA4 option, so it is not possible to combine 4-20 mA I/O channels with Ethernet based advanced communications.

The 4-20 mA input and output circuits are isolated from each other and all other circuits in the actuator, allowing unrestricted placement in any 4-20 mA loop. The isolated parts of the circuits are “loop powered” meaning that each circuit uses a small amount of power as voltage drop from the 4-20 mA loop, and uses that to generate the internal power supplies needed.

4.14 4-20 mA INPUT

As with the voltage analog input, the 4-20 mA input may be used as a position, velocity or current command. It can also be used for a Velocity Override feature to dynamically moderate velocity during a move.

The 4-20mA input circuit requires a minimum of 11 V of available loop voltage to operate. There is a fixed 5.6V drop plus 258 Ohms of loop resistance. The circuit reaches full accuracy when the input reaches 3 mA. Except during power-up and power-down, keep the signal presented to the input circuit between 3 mA and 21 ma. Loss of Signal settings are generally set a little below 4 mA and a little above 20 mA. If there is too little voltage to power all devices in a 4-20 mA loop, the actual current will reach a maximum below the intended current. The TTX080 input channel will continue to report the actual current, if over 3 mA.

When the 4-20 mA loop is unpowered, the software reads an off-scale low value near 2 mA, not 0 mA. A signal with current above a value near 22 mA will also read as 2 mA. Therefore it is important to consider what should be done when an out of range signal is encountered.

The 4-20 mA input circuit is calibrated at the factory for accuracy and should not be recalibrated without proper equipment. Often what is desired is to match the source value before converting it to a 4-20 mA signal to the value used in the actuator. Rather than re-calibrating, this can be adjusted using scaling in either of two places using Expert software. The analog input is not used directly, but is converted to a 0% to 100% value on the IA4 Option Board page, Input Setup tab. This is the best place to make small scaling adjustments. The value is scaled again into position, velocity, or current units where used

4.14.1 4-20 mA Input Connection

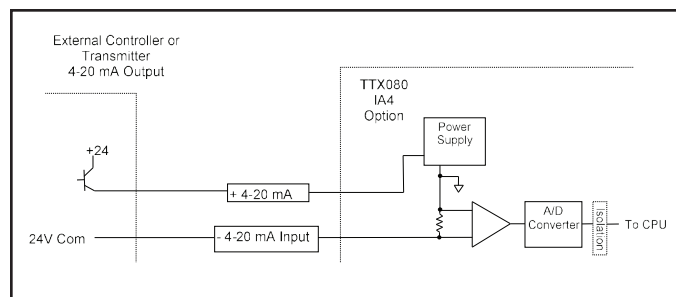

Figure 24 – Connection to High Side Controller

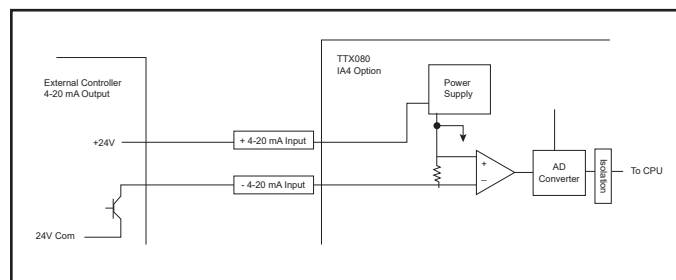

Figure 25 – Connection to Low Side Controller

4-20 mA Input Specifications

Description	Specification
Input Range	3 mA to 21 mA
Voltage drop at 20mA	11V max
Input Accuracy	+/-0.1 % of 4-20 mA span
Input Resolution	>14 bits over 4-20 mA span
Update Rate	0.5 ms

4.15 4-20 mA OUTPUT

The 4-20mA output channel, like the voltage Analog Output may be configured for position, velocity or current monitoring, and can be dynamically switched between two sources. Details for configuration are in the Expert Software Manual.

The 4-20 mA output is an isolated two wire circuit requiring an external loop power supply. The TTX080 circuit requires a minimum of 8 V to operate and can tolerate up to 30 V. The best approach to determining whether a particular loop will

have enough voltage is to determine the voltage required for each device in the loop at 20 mA and make sure the loop power supply has enough voltage. If using a typical 24V source for the loop and having only one input device along with the TTX output, it would be highly unusual for a loop to run out of voltage. However, if an output of 20 mA is expected from the TTX and the actual loop current is less, check that there is enough loop voltage. If the 4-20 mA input circuit appears as a resistance, the maximum resistance that may be used depends the loop supply voltage. It is possible to convert the 4-20 mA signal into a voltage by running it through a precision resistor.

Loop Supply Voltage	Maximum Impedance @ 20 mA	Minimum Impedance @ 20 mA
12 V	200 Ω	200 Ω
15 V	350 Ω	200 Ω
24 V	800 Ω	200 Ω
30 V	1100 Ω	200 Ω

If the TTX actuator is powered down, the isolated part of the 4-20 mA output circuit could remain active since it is powered separately. A watchdog feature sets the 4-20 mA output to an off-scale low output of approximately 2mA when actuator main and logic power are removed.

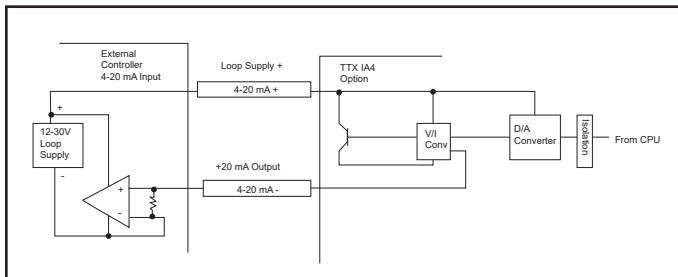

Figure 26 – 4-20mA Output Connection

4-20 mA Output Specifications:

Description	Specification
Output Current Range	3 – 21 mA
Load Range	200 to 1100 Ω (see table above)
Output Accuracy	+/-0.2% of span
Output resolution	12 bits
Update rate	0.5 ms

4.16 ABSOLUTE FEEDBACK

The TTX080 comes standard with multi-turn absolute position feedback. The system consists of a base magnetic feedback system that is always absolute over one turn and a low power battery-backed multi-turn counter. The counter will track the motor's position, as long as battery voltage is present. Multi-turn absolute feedback allows a system to be powered off and re-started without having to re-establish a position reference through a Home move or manual positioning, even if a machine is packed up and relocated.

The multi-turn absolute position feature can be disabled and the low battery condition ignored, if desired. The battery can then be removed eliminating the need for any battery maintenance. Keeping I/O power on continuously can also maintain a position reference under most conditions and provides some other advantages in a system.

4.17 BATTERY LIFE INFORMATION

Battery Life is typically 2 years from time of product purchase.

4.17.1 Low Battery Voltage

When the battery voltage gets below 3 V, a low battery condition will be set. This condition is typically set to generate a warning status on the Fault Enable tab of the System Setup page. The warning status can then be assigned to one of the outputs. The battery voltage can be displayed on the Diagnostic page while on-line with the actuator, or read by any communications connection. The type of battery used will only have about 1% of charge remaining when this indication occurs.

When battery voltage gets too low to maintain the count value the Homed Status will be off on the subsequent power up, requiring the actuator to be re-homed. A low or dead battery does not keep the system from running. It just means a Home will be required after a power-down.

4.17.2 Replacing the Battery

After removing AC power to actuator, remove the wiring access cover. To avoid loss of absolute position information if that is important, keep main or logic power applied. Unplug the two pin battery connector from the Termination Board and pull the battery out of the clip. The replacement battery kit is Exlar P/N 54108. Center the replacement battery on top of the clip and gently push it into the clip with a little rolling motion. Then plug in the two pin connector.

4.18 ETHERNET OPTIONS, EIP, TCP OR PROFINET IO

The Ethernet Options EIP, PIO, or TCP in the model mask provide an Ethernet rated M12 connector for connection to the Network at the rear of the actuator.

An IP 67 4-pole M12 D coded connector is used, this type of connector must only be used with two pair cables. When the Ethernet connection is made via an Ethernet switch or hub a straight through cable set must be used. If there is a single node connection direct from the Ethernet PC/PLC to the TTX080 then a crossover cable may be required. Some PC Ethernet cards have capability to detect a crossover connection. See Expert Software manual for setup of TTX080 Ethernet parameters and Ethernet/IP or ProfiNet IO manuals for network specific setup information.

Cord sets

	Signal Name	
1	Transmit + (TX+)	Pair
2	Pin	
3	Receive + (RX+)	Pair
4	Receive - (RX-)	

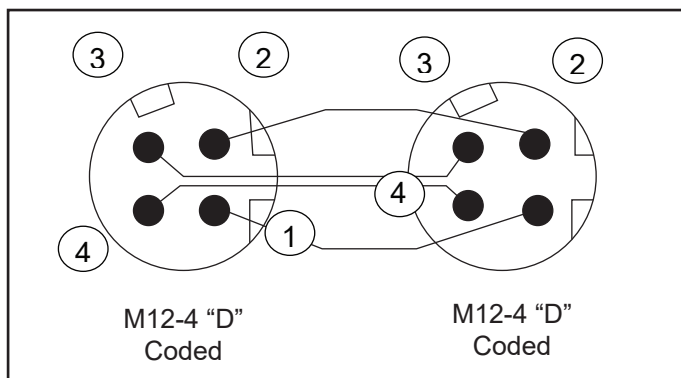

Figure 27 – M12 D Coded Straight Through Cord Set

8-Way Modular	M12	Signal	
1	1	TX+	Pair
3	2	TX-	
2	3	RX+	Pair
6	4	RX-	

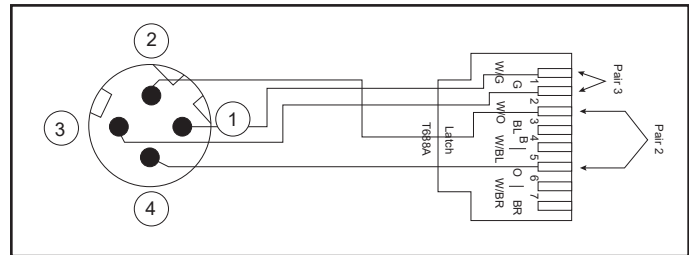

Figure 28 – Conversion from M12 D Coded to 8 Way Modular Straight Through Cord Set

For Options EIN, PIN or TCN in the model mask the M12 connector is not included; the Ethernet CAT 5 cable must be routed through the M20 IO port. The installer must then crimp on an RJ45 8 way Modular connector for installation to Ethernet port inside the wiring access area.

8-Way Modular	Signal	
1	TX+	Pair
3	TX-	
2	RX+	Pair
6	RX-	

4.19 SHIELDED OR UNSHIELDED CABLES

The TTX080 can be used with either shielded or un-shielded Ethernet cables. If a shielded cable is used it is important that the shield is not connected at the TTX080 M12 end of the cable. Off the shelf shielded Ethernet cables with M12 connectors usually connect the shield through the M12 connector coupling nut, be sure the shield is not connected to the TTX080 end of the coupling nut. The TTX080 M12 connector is in direct contact with the enclosure which is connected directly to PE. Typically the shield should be connected to PE at the switch or hub end only. Connecting the shield at both ends can cause ground loop noise on the shield which can degrade communication performance.

For more details on the installation of an Industrial Ethernet network download the EtherNet/IP Media Planning and Installation Manual, found in the EtherNet/IP library at www.ODVA.org.

5.0 MAIN POWER SUPPLY SELECTION

The TTX actuator requires DC power from a power supply or batteries. The actuator will operate on voltages from 12-48V DC nominal. The continuous operating range is 10-53V DC. If the bus voltage rises above 85 V DC a High Bus Fault will occur and the drive will disable. The voltage threshold may be set lower through a user parameter where appropriate to protect a power supply from overvoltage during regen. The power supply output current rating depends on the maximum actuator power required for the installation.

A 48V supply will allow the motor to deliver maximum rated speed, (specifications in Overview section) a 24V supply will allow the motor to deliver $\frac{1}{2}$ the maximum rated speed, and a 12V Supply will allow the motor to deliver $\frac{1}{4}$ the maximum rated speed.

Power supply selection and connection is complicated by three factors associated with variable speed servo drives: high peak loads, power regeneration (regen) and switching frequency ripple current. Peak loads and regen will depend on the application. Ripple current can adversely affect some power supplies.

Note: This section does not pertain to an I/O or Holding Brake Power Supply. The I/O supplies have different limits and it is often inappropriate to use the same supply for all. See section on I/O Supply.

Power supply sizing for motion is based mainly on maximum mechanical power delivered to the load, which is force times velocity for linear or torque times angular velocity for rotary. The power supply has to provide this power which is rated voltage times maximum current plus about 20% to cover losses. Either regulated or unregulated power supplies can be used for the bus and logic power. Different considerations pertain to each type, and each has advantages and disadvantages. Exlar offers a 48V unregulated supply rated at 10 amps continuous output, TTPS1048 (see Accessories section). It can deliver about 450W continuous output power. Due to its higher output voltage at light load, it may be necessary to connect to a higher voltage tap, such as the 132V tap for 120V operation. This supply requires an external fuse in the AC input.

5.1 UNREGULATED AC/DC POWER SUPPLIES

TTX DC operates well from a transformer isolated, unregulated DC power supply. This type of supply should be sized and connected such that the maximum output voltage under high-line and light-load conditions does not exceed the drive maximum voltage rating, 48V + 10%. For instance, when using the TTPS1048 power supply, if the line voltage ever rises above 120V AC, the supply should be connected for 132V AC operation to lower the output voltage by 9%.

Unregulated supplies have the advantage of being able to supply peak currents without overloading and will not trip on high voltage. Unregulated supplies have larger capacitance at the output, especially when compared to regulated switching supplies, providing greater energy recovery and storage during regen and tolerating high ripple current. See section on regen for more information on handling energy from regeneration. They have the disadvantage of output voltage droop as the current rises.

Unregulated supplies are usually rated only by continuous output current. For a very short time, not exceeding 1 second, they can typically output up to 200% of continuous current. Voltage droop may be significant above continuous voltage rating, which can reduce maximum speed. One sizing technique is to calculate the required average power over the worst 5 second interval in a machine cycle, add 20% and use that to determine continuous rated output power for an unregulated supply.

5.2 REGULATED AC/DC POWER SUPPLIES

Most AC/DC power supplies available today are regulated switching power supplies. They are generally not designed to directly power brushless DC (BLDC) drives, but can do so with special consideration for the load that BLDC drives present to the supply and the overload characteristics of the power supply. These supplies provide very good output voltage regulation as well as high efficiency and smaller size and weight compared with unregulated linear supplies.

Due to overcurrent protection, regulated supplies must generally be rated for the peak power required by the drive. Because the supplies limit output current, fuses between power supply and drive may not be able to interrupt fault current to the drive. The power supply must have output current foldback and / or output cycling on overload. Foldback is where the output current limit is reduced more or less proportionally with

the output voltage. Output cycling removes all output power on overload and waits a few seconds before attempting to restore power, limiting average power during faults. Fuses can still be very useful in isolating a fault when a large power supply is used to power several loads. Where conditions of use by an approval agency require fuse protection, the fuses must be installed even if they would not immediately clear a fault.



CAUTION! During deceleration of the load the energy generated from the motor and the load will increase the bus voltage and could possibly damage the output of a regulated power supply. If a regulated power supply is used for bus power, a blocking diode should be installed to protect the power supply. See Power Supply Wiring Diagrams section below

Regenerative energy due to deceleration, spring action, or gravity on the mechanical load will increase bus voltage and attempt to drive energy backward into a power supply. Regulated supplies may trip on overvoltage or recover slowly after being out of regulation causing a dip in output voltage at the end of a regen event. It may be necessary to use a blocking diode to allow the bus voltage at the drive to rise above normal supply voltage without any reverse current. Exlar offers a Power Distribution and Surge Filter assembly that include a blocking diode, TDCESEF1 (see Accessories section). See the section below on Handling Regen Energy

Another aspect of BLDC drive loads is that it tends to take pulses of current at twice internal switching frequency creating high ripple current. Some regulated supplies may not be able to tolerate high ripple current, depending on the final filter capacitors. The Power Distribution and Surge Filter assembly includes a small inductor that reduces ripple current. The blocking diode (if used) also reduces ripple current. Power wiring or power cables more than 30 ft (10 m) long provide enough impedance to reduce ripple current as well. Contact Exlar applications support for additional information.

5.3 POWER FROM BATTERY SYSTEMS

TTX DC is designed to be powered directly from 12V and 24V lead-acid batteries or other battery systems. Regen energy and ripple current are not generally of concern with battery applications of this type. Battery systems generally will be able to supply peak power to the actuator. The average power may be a consideration in sizing the charging circuits for the battery system. Other battery powered applications are possible, but would require additional engineering considerations.

The product has not been tested for immunity to “load dump” conditions. An external voltage clamp designed specifically for load dump protection may be necessary on 24V systems.

5.4 HANDLING REGEN ENERGY – INTERNAL SHUNT RESISTOR AND REGULATOR

TTX DC has a built in controller and small internal shunt resistor that can handle up to 10 joules of energy at a time as long as average power does not exceed 8W. Though not high capacity, it is adequate to handle the inertia for many linear applications. It is usually inadequate to handle energy from a vertical load or spring return. The controller will turn off the shunt upon reaching either energy or power limits. If there is more regen energy, the bus voltage will rise, resulting in a high bus fault.

Note: A poorly tuned system may have some oscillation that results in the bus voltage pumping up and down enough to turn on the shunt. This reduces the available capacity for handling expected energy from deceleration. Likewise, if an overly aggressive move profile results in significant following error, there can be velocity overshoot followed by deceleration that causes unnecessary regen energy to reach the internal shunt resistor.

As shipped from the factory the internal regulator is set to a value to protect the TTX from an overvoltage fault condition (85 V). This parameter will not require adjustment as long as the power supply can be back-driven to 85 V like most unregulated 48 V supplies, or can handle all the regen energy like most battery applications, or is isolated with a blocking diode. For other applications, the built in regulator can be adjusted to restrict bus voltage to a level that will protect the power supply from regen energy. Set the User Overvoltage Fault Limit Parameter found in Expert software on the System Set-up page / Limits tab to a value that the power supply can tolerate. The TTX shunt regulator will operate at 90% of the User Overvoltage Fault Limit value. The drive will trip with a High Bus Voltage fault at the User Overvoltage Fault Limit value or at 85 V, whichever is lower. The default setting of 0 is a special case that means the factory parameter values of 85 V for trip and 76.5 V for shunt operation will be used.

In the example below a single 24 volt regulated supply is used for main power (BUS+), and Digital I/O. Logic power is derived internally from the bus power. The 24 volt regulated supply will keep the I/O voltage under the 30 volt limit but not within limits for the brake option, so may not be suitable for units with a brake. Notice there is no external diode, isolating the power

supply from the Bus voltage. For this example, set the User Overvoltage Fault Limit to 33 V. The TTX shunt regulator will attempt to limit the Bus Voltage to 30 volts (90% of 33 V) to protect the power supply from overvoltage faults & shutdowns and the I/O from overvoltage. If the regen energy is too large, the shunt regulator will turn off to protect itself and a high bus voltage fault will occur at 33 V, disabling the drive and protecting the power supply and I/O circuits.

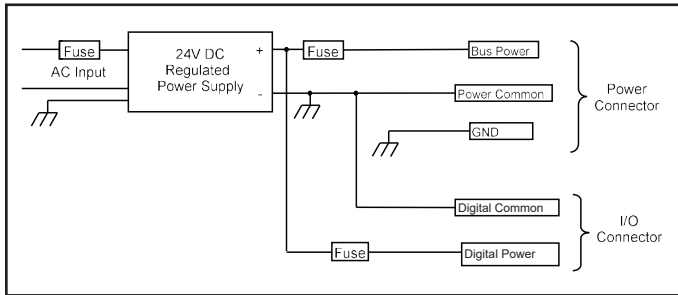

Unregulated supplies often have very large capacitors that can store regen energy if allowed to be back driven. This characteristic can be used in conjunction with the internal shunt resistor and regulator. The shunt operating point is set to the working voltage of the capacitors. Regen energy is stored in the capacitor until its voltage rises to the shunt operating point. Then the internal shunt accepts up to 10 J of additional energy.

5.5 HANDLING REGEN ENERGY – EXTERNAL SHUNT RESISTOR AND REGULATOR

For applications lowering vertical loads or decelerating a large inertia or working to hold back some force, regen energy will exceed the ability of the internal shunt resistor and power supply to dissipate or store it. The TTSR1 Shunt Regulator can handle at least two hundred joules of energy at up to 95 Watt average power. It has a fixed operating voltage of 77V, so the power supply must be able to be back driven to more than this voltage or a blocking diode is required. The TDCESF1 Power Distribution and Surge Filter accessory may be used to simplify wiring when an external shunt regulator is used with single or multiple TTX DC.

5.6 LOGIC POWER SUPPLY

A logic power supply can be used to maintain the control and position information with bus power removed. This power supply is optional and requires about 2 watts of power. It is wired to the Logic Power terminal (+) and Power Common terminal (-). If it is not connected the logic power will come from bus power. Note that the main power and logic power share a return path. Logic Power can be the same wide range as the main power supply, 12 V, 24 V, or 48 V nominal, and can handle the regen voltages

that appear on the main supply. A single supply may be used for both with a relay contact in series with the main supply positive connection to remove bus power. As long as the main power supply and an I/O Supply have negative terminals grounded, the I/O supply may be used for logic power.

5.7 POWER SUPPLY WIRING DIAGRAMS



WARNING! All installations should provide a method of removing bus power during an emergency stop condition. The actuator enable function should not be relied on for this function when equipment or personnel safety is required. Disconnect only the + bus power; do not disconnect the – bus power.

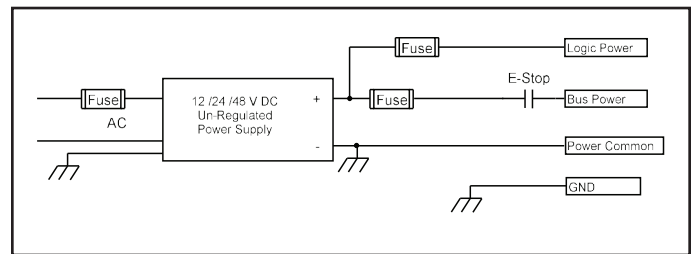

Figure 29 – Un-Regulated Power Supply for Logic and Bus Power

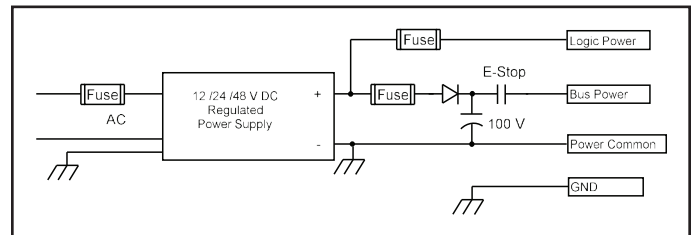

Figure 30 – Regulated Power Supply for Logic and Bus Power, with Diode Isolation and Optional Extra Capacitance

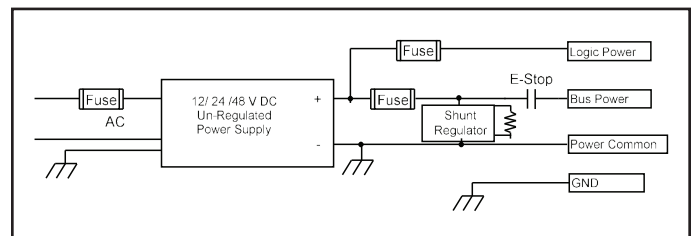

Figure 31 – Un-Regulated Power Supply for Logic and Bus power, with a Shunt Regulator Such as Exlar TTSR1

CAUTION! Reversing polarity of the Bus Power (+) and Power Common (-) will cause a short circuit, which must be protected by the input fuse. See fusing below. If a fuse is not installed the drive could be permanently damaged.

Power Supply Wiring and Fusing

	Fuse	Wire
Bus Power	20 amp 125 V dc. Bussmann type ABC or similar.	12 gauge (4 mm ²)
Logic Power	2 amp 125 V dc. Bussmann type ABC or similar.	18 gauge (1,5 mm ²)

Twelve gauge wire is recommended for bus power to reduce voltage drop across the wire during peak power demands. If the application does not require high peak or continuous power, the wire gauge can be reduced, with a corresponding reduction in fuse rating.

WARNING! If the wire gauge for bus power is reduced the fuse Amp rating must also be reduced in accordance with wire size, type and local regulations.

5.8 GROUNDING

WARNING! The actuator and all power supply PEs and negative connections must be properly grounded using a single point grounding method.

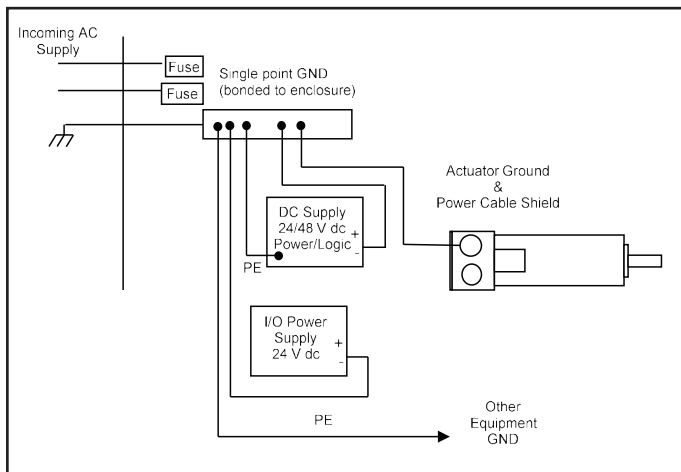

Figure 32 – Grounding Diagram

5.9 POWER SUPPLY CONNECTIONS

Power Connector Pin-Out, M23 Connectors, “I” Connector Option

Signal	Pin for “I” Connector Option	Wire Color	
		TTIPC	“B” Option
Bus Power (+) 12-48 V dc	1	Blue	Red
Logic Power (+) 12-48 V dc	3	White	Blue
Power Common (-)	4	Black	Black
PE (GND)	2	Green	Green
N/C (Reserved)	A	Orange	N/A
N/C (Reserved)	B	Red	N/A
N/C (Reserved)	C	White/Black	Light Blue
N/C (Reserved)	D	Red/Black	Light Blue/White

Front View “I” Connector Option

Insulation inserts:
E-Type, Front View



Power Connections on Terminal board 80 mm

Signal	Terminal Label	Minimum Wire AWG.
Bus Power (+) 12-48 V dc	Bus +	12
Power Common (-)	COMMON	12
Logic Power (+) 12-48 V dc	LOGIC +	18
PE (GND)	PE	12

6.0 STARTUP

6.1 CONSIDERATIONS FOR STARTUP

6.1.1 Safety Considerations



CAUTION! Do NOT exceed the maximum input voltage for TTX Series DC powered actuators (48 Vdc).

6.1.2 Rotary-to-Linear Motion Relationship

The relationship between the rotary motion of the motor and the linear motion of the actuator is based on the following parameters:

$$L_D = Rev \times R$$

$$L_S = [RPM/60] \times R$$

$$L_F = [T \times (2p \times E/R)]$$

where:

E = Efficiency

L_D = Linear distance traveled

L_S = Linear speed

L_F = Linear force

R = Roller screw lead

REV = Motor revolutions

RPM = Motor revolutions per minute

T = Motor torque

NOTE: Each of the above relationships requires proper anti-rotation of the actuator rod.

6.2 GENERAL STARTUP PROCEDURE

IMPORTANT! Exlar recommends testing new systems prior to live operation (see Expert Software manual for startup procedure).

1. A CD is provided with each actuator and contains the Expert software and manual. The software is also available to download from www.exlar.com.
2. The Expert software will need to be installed on your PC.
3. Follow the software installation and setup instructions contained in the Expert Software manual.

NOTES:

- TTX Series actuators can be operated at current levels two times the current rating for short amounts of time.
- When operating the actuator in the peak current range, follow the duty cycle limits shown in below.

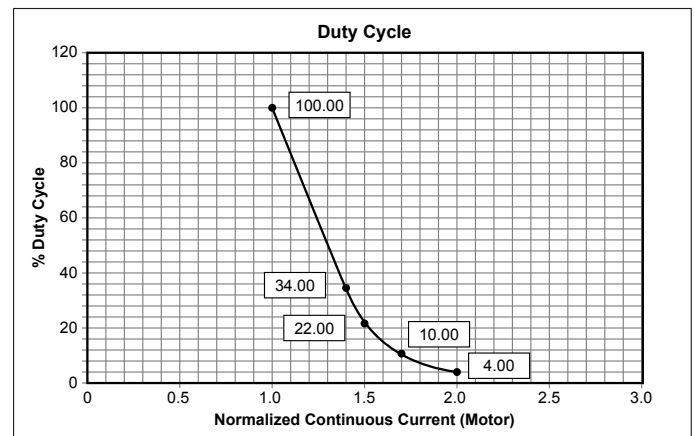

Duty cycle for peak current operation

7.0 MAINTENANCE PROCEDURES

7.1 LUBRICATION

TTX Series actuators lubricated with grease require periodic inspection and renewal of the bearing and roller screw grease to maximize actuator life. Maintenance indicators during a physical inspection include:

- Contamination of grease with foreign matter
- Leaking seals
- “Burnt” smell of the grease
- Grease is gritty in appearance
- Grease is dehydrated (dried out)

Although application-specific performance makes it difficult to provide an exact number of hours of operation before maintenance is required, the following factors will help determine lubrication maintenance cycles.

Temperature – Temperature is the most significant factor affecting grease life. Exlar’s testing of Mobil SHC 220 synthetic grease indicates ideal performance operation in ambient temperature ranging from 32° C to 55° C (90° F to 130° F). Within this temperature range, the grease has a long service life. Operation in temperatures above this range decreases the effective grease life. For every temperature rise of 15° C (60° F), grease life is reduced by approximately 50%.

Speed – The rotational speed of the actuator will generate heat (thus raising the grease temperature) and potentially resulting in lubricant being thrown off the roller screw.

Load – Load contributes to the stress applied to the roller screw mechanism and the pressure applied to the grease thus impacting the overall lubricant life and relubrication interval. Load directly impacts the amount of power put into the actuator adding to the heat generated by roller screw speed. This heat is transmitted to the lubricant eventually separating the oils from the thickener and reducing grease life.

Orientation – Gravity can cause grease migration over time, especially in vertical applications at elevated temperatures. The table below provides a general guideline for recommended lubrication renewal cycles.

RMS Rotational Speed (RPM)	Recommended Grease Renewal Period (hours)		
	Case Temp. 65° C (149° F)	Case Temp. 80° C (176° F)	Case Temp. 95° C (203° F)
250	10,000	5,000	2,500
500	8,500	4,250	2,125
1000	6,000	3,000	1,500
1500+	3,500	1,750	875

Recommended lubrication renewal cycles

Grease renewal procedure

1. Remove the four bolts connecting the faceplate and any mounting accessories from the front of the actuator.
2. Remove the roller screw by turning it counter clockwise and threading it out of the cylinder. To remove the screw, it may be necessary to hold the roller screw cylinder to keep it from turning. Turning the shaft will help force the faceplate assembly to break free of its housing.
3. Use a brush to work approximately 10 cm³ (0.6 in³) of grease into the roller screw assembly for every 100 mm (3.9 in) of stroke length. Be sure all the threaded surfaces of the screw assembly are covered. This can be accomplished by applying grease to a few places on the roller screw assembly and rotating the components repeatedly in both directions to work the grease into the assembly. **IMPORTANT!** Excess grease does not improve lubrication and requires greater torque when the motor is returned to operation.
4. With the actuator in the vertical position and the open end of the roller screw cylinder facing up, position the roller screw above the cylinder so that it is aligned axially with the roller screw cylinder.
5. Slowly turn the roller screw clockwise in ¼- to ½-turn increments while maintaining contact with the interior threaded cylinder (ITC). This helps align the threads on the roller screw with the threads in the ITC. Do NOT force the roller screw into the cylinder.

If the roller screw does not turn freely, remove it and begin again. When the screw is properly threaded into the cylinder, it will roll freely into the actuator. **NOTE:** When the roller screw reaches the portion of the cylinder that contains the motor magnets, it will be more difficult to turn because of the magnetic field of the magnets. THIS IS NORMAL. Continue to thread the roller screw into the cylinder until it reaches the bottom (it will become difficult to turn and the motor and bearings will begin to rotate with it).

6. Place a small amount of seal lubricant on the inside surface of the seal/bushing assembly.
7. Carefully slide the faceplate over the actuator rod end while guiding the four cap screws through their respective holes in the rear end cap of the actuator. Ensure the faceplate seats completely and squarely on the front of the actuator. **NOTE:** The seal is a tight fit on the rod end. Use caution to avoid damaging the seal on the threads of the extending rod. The inner surface of the faceplate provides the pre-loading for the bearings, so it is important that it be properly seated. Torque the four cap screws of the faceplate assembly to 12.2 Nm (9 ft-lb).
8. For actuators equipped with an external anti-rotate mechanism and/or limit switch assembly, slide the rod of the anti-rotate mechanism rod into the guide bushing. Tighten the two screws used to hold the anti-rotate assembly or the four screws used by the limit switch assembly to clamp that assembly to the actuator rod.

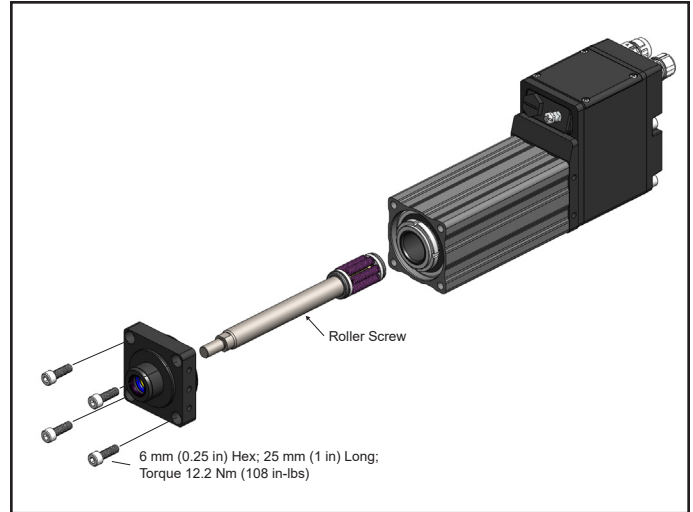
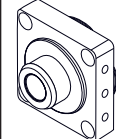

Figure 33 - Grease renewal reference

7.2 SEAL MAINTENANCE

Exlar recommends that the faceplate assembly containing the main rod seal and bushing assembly be replaced during the re-lubricating procedure. To have this service performed for you, contact the Exlar Returns Department to send your unit in for service (see Section 9.0, "Product Returns"). If any additional maintenance or repair is needed, consult Exlar. It may be necessary to return the actuator to the factory for refurbishment.

7.3 REPLACEMENT FACEPLATE ASSEMBLY KIT

Faceplate	Model	Part Number	Parts Included
	TTX080	PN 71457	Faceplate, O-ring, bushing, seal, wiper, and fasteners

Faceplate Assembly Kit

8.0 TROUBLESHOOTING

TTX Series actuators are engineered for years of trouble-free operation. If problems are encountered while installing or using the actuator, the information in the guidelines below may help solve the problem.

Troubleshooting guidelines

Symptom / Trouble	Possible Cause / Troubleshooting Procedure
No response from actuator.	<ol style="list-style-type: none">1. Connect to Expert software and check operating mode, fault, and status information2. Check for proper wiring
Actuator cannot move load.	<ol style="list-style-type: none">1. Load is too large for the capacity of the actuator or too much friction is present2. Excessive side load3. Misalignment of output rod to load
Actuator housing moves or vibrates when shaft is in motion.	<ol style="list-style-type: none">1. Check actuator mounting. Insure that the actuator is securely mounted2. Check tuning
Output rod rotates during motion and thus does not provide proper linear motion.	<ol style="list-style-type: none">1. Install Exlar anti-rotation assembly or incorporate anti-rotation into the application
Brake does not hold load in place.	<ol style="list-style-type: none">1. Load is larger than the capacity of the brake-check load level against actuator rating2. Brake is being used as other than a power loss holding brake and now is worn out
Actuator is overheating.	<ol style="list-style-type: none">1. Insufficient cooling for application requirements2. Actuator is being operated outside of continuous ratings3. Amplifier is poorly tuned causing excessive unnecessary current to be applied to motor. Refer to tuning information through Expert software

9.0 CABLE ACCESSORIES

9.1 TTIOC-xxx I/O CABLE

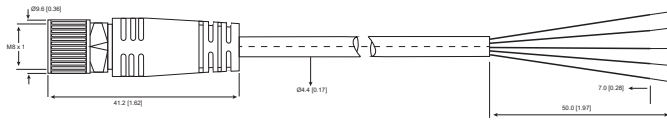
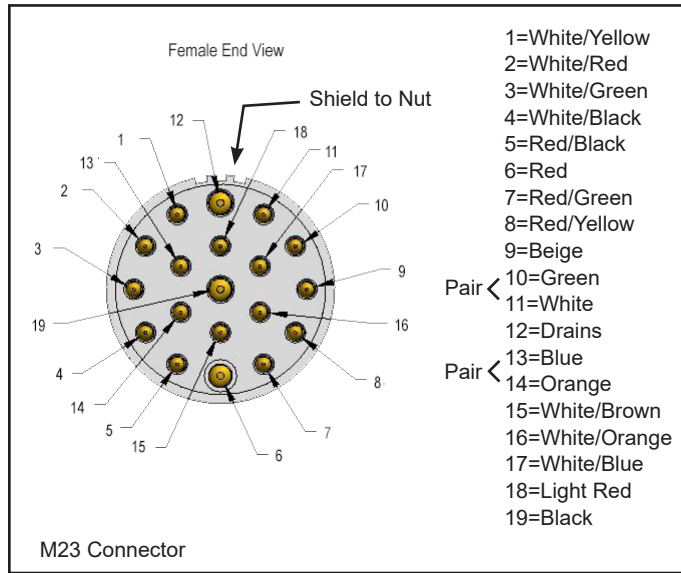

Specifications	
Contact Carrier Material / Color	Nylon or PBT / Gray
Molded Head Material Color	Thermoplastic Pur / Black
Contact Material / Plating	Brass / Gold
Coupling Nut Material / Plating	Brass / Nickel
Rated Current [A]	3.0 A
Rated Voltage [V]	150 V
Outer Jacket Material / Color	PVC / Black
Conductor Insulation Material	PVC
Number of Conductors [AWG]	18 X 22 AWG / 2X22 AWG Drain
Shield / Braid	Aluminum Foil Shield / T-C Braid
Temperature Range	-40°C to +105°C (-40°F to +221°F)
Protection Class	IEC IP67

9.2 CBL-TTIPC-SMI-XXX POWER CABLE

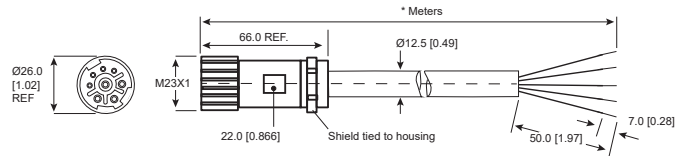
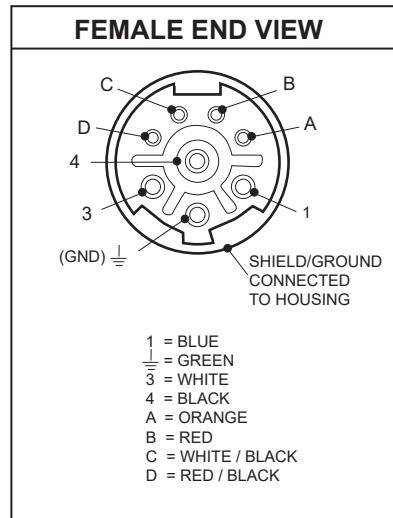

Specifications	
Contact Carrier Material	Nylon
Contact Material / Plating	Brass / Gold
Housing Material / Plating	Brass / Nickel
Rated Current [A]	24A (1-4), 8A (A-D)
Rated Voltage [V]	600 V
Outer Jacket Material / Color	PVC / Yellow
Conductor Insulation Material	PVC
Number of Conductors [AWG]	5x14 AWG
Drain / Shield	18 AWG / Foil and Tinned - Copper Braid
Temperature Range	-40°C to +105°C (-40°F to +221°F)
Protection Class	Meets IEC IP67

9.3 TTICO-xxx COMMUNICATIONS CABLE

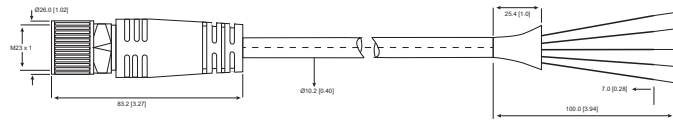
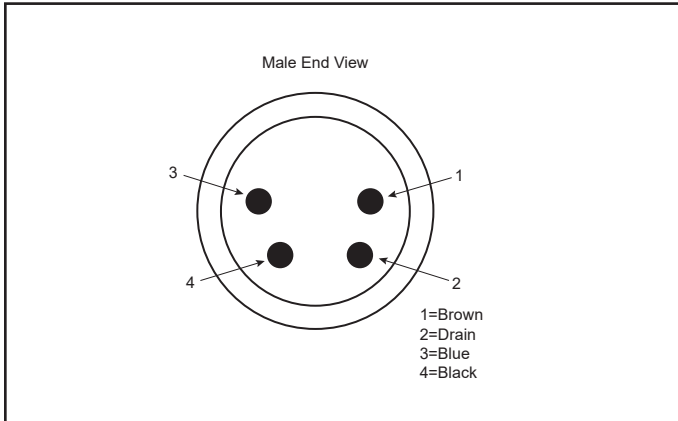

ready to connect to the TTX080 port. Model # CBL-T2USB485-M8-xxx. This converter is not isolated and is not recommended for permanent installation.

CAUTION! If another master is on the network such as PLC or HMI, this converter must be removed from the RS485 end. Leaving it connected with the USB end unconnected will load down the RS485 network and not allow it to function.



Specifications	
Contact Carrier Material / Color	Nylon or PUR / Black
Molded Head Material Color	Thermoplastic Pur / Yellow
Contact Material / Plating	Brass / Gold
Coupling Nut Material / Plating	Brass / Nickel
Rated Current [A]	2.0 A
Rated Voltage [V]	125 VAC / VDC
Outer Jacket Material / Color	PUR / Black
Conductor Insulation Material	PVC
Number of Conductors [AWG]	3X24 AWG
Drain / Shield	26 AWG Drain / Foil
Temperature Range	-40°C to +105°C (-40°F to +221°F)
Protection Class	Meets NEMA 1, 3, 4, 6P & IEC IP67

Communication Converter

When connecting the TTX080 RS485 port to PC, a communication converter will typically be required.

Exlar offers a USB to RS485 converter with an M8 connector

10.0 PRODUCT RETURNS

Procedure to return products for repair or replacement:

1. Before requesting an RGA number, please contact Exlar Technical Support to see if it is possible to resolve the issue prior to return.
2. If it is determined that an RGA number is required, please do so by completing an online RGA request form found on the Exlar website. For international repairs, closely follow instructions provided by the Exlar Returned Goods Administrator. Failure to comply with issued instructions may result in delays for repair and return.

11.0 CERTIFICATIONS

EU Declaration of Conformity

This declaration is issued under the sole responsibility of the manufacturer.

<i>The undersigned, representing the Manufacturer Exlar Corporation 18400 West 77th Street Chanhassen, MN 55317 USA</i>	<i>and the authorized representative established within the community Exlar GmbH Frankfurter Str.: 107 65479 Raunheim, Germany</i>
--	--

*Declares, that the Exlar Brand Products:
TTX Powered Linear Actuators*

*(Complete Model Listing Below)
Model identification:
TTX080-xxx-xx-x-x-D-xxx-x-x*

*The objects of the declaration described above is in conformity with the relevant
Union harmonization legislation.*

Per directives listed below:

*EU EMC Directive 2014/30/EU
EU RoHS 2011/65/EU and amended with Directive 2015/863*

Using the relevant section of the following EU standards and other normative documents:

*EMC: EN 61800-3:2004+A1:2012 Adjustable Speed Electrical Power Drive
Systems – Part 3: EMC Requirements and Specific Test Methods.*

Year of CE Marking: 2018

*Note: The above product operates at less than 75 VDC and thus
is not subject to the requirements of the Low Voltage Directive.*

Signature: 
Name: Robert Panning
Position: Manager Product Development, Engineering
Date of Issue: July 30th, 2018

NOTE: TTX Series actuators that are intended as components in a third-party machine in which the enclosure and assembly will affect the EMC emissions, are covered by the EMC standard that relates to the final product.

Per EU directives implemented on April 20th, 2016, the following procedures must be followed by importers and distributors.

IMPORTER REQUIREMENTS

- Importers shall indicate their name, registered trade name or registered trade mark, and the postal address at which they can be contacted on the apparatus (unless that is not possible, in which case it should be included on the packaging or in an accompanying document).
- Importers shall ensure that the product is accompanied by instructions and safety information in a language which can be easily understood by end-users, as determined by the Member State concerned.
- Importer is to translate the EU declaration of conformity into the languages required by the member state(s), where the product is sold. Importers shall keep a copy of the EU declaration of conformity for 10 years.
- Importers shall provide a reasoned request from a competent national authority and provide it with all the information and documentation in paper or electronic form necessary to demonstrate the conformity of a product in a language which can be easily understood by that authority.
- Importers shall ensure that, while apparatus is under their responsibility, its storage or transport conditions do not jeopardize its compliance with the safety objectives.
- Importer shall take corrective action necessary when they consider or have reason to believe that the product is not in conformity with its directive(s).

DISTRIBUTOR REQUIREMENTS

- Distributors shall indicate their name, registered trade name or registered trade mark and the postal address at which they can be contacted on the apparatus (unless that is not possible, in which case it should be included on the packaging or in an accompanying document).
- Distributor shall ensure that apparatus is accompanied by instructions and safety information in an appropriate language. Distributor shall translate the EU declaration of conformity into the languages required by the member state(s), where the product is sold. Distributors shall keep a copy of the EU declaration of conformity for 10 years.
- Distributor shall ensure that, while apparatus is under their responsibility, its storage or transport conditions do not jeopardize its compliance with the safety objectives.
- Distributor shall take corrective action necessary when they consider or have reason to believe that the product is not in conformity with its directive(s).

12.0 WARRANTY AND LIMITATION OF LIABILITY

Products are warranted for two years from date of manufacture as determined by the serial number on the product label. Labels are generated and applied to the product at the time of shipment. The first and second digits are the year and the third and fourth digits represent the manufacturing week. Product repairs are warranted for 90 days from the date of the repair. The date of repair is recorded and tracked by individual product serial number.

Exlar Corporation (“Exlar”) warrants its product(s) to the original purchaser and, in the case of original equipment manufacturers, to their original customer, to be free from defects in material and workmanship and to be made only in accordance with Exlar’s standard published catalog specifications for the product(s) as published at the time of purchase. Warranty or performance to any other specifications is not covered by this warranty unless otherwise agreed to in writing by Exlar and documented as part of any and all contracts, including but not limited to purchase orders, sales orders, order confirmations, purchase contracts and purchase agreements. In no event shall Exlar be liable or have any responsibility under such warranty if the product(s) has been improperly stored, installed, used or maintained, or if Buyer has permitted any unauthorized modifications, adjustments and/or repairs to such product(s). Seller’s obligation hereunder is limited solely to repairing or replacing (at its opinion), at the factory any product(s), or parts thereof, which prove to Seller’s satisfaction to be defective as a result of defective materials, or workmanship and within the period of time, in accordance with the Seller’s stated product warranty (see Terms and Conditions, above), provided, however, that written notice of claimed defects shall have been given to Exlar within thirty (30) days from the date of any such defect is first discovered. The product(s) claimed to be defective must be returned to Exlar, transportation prepaid by Buyer, with written specification of the claimed defect. Evidence acceptable to Exlar must be furnished that the claimed defects were not caused by misuse, abuse, or neglect by anyone other than Exlar.

Components such as seals, wipers, bearings, brakes, bushings, gears, splines, and roller screw parts are considered wear parts and must be inspected and serviced on a regular basis. Any damage caused by failure to properly lubricate Exlar products and/or to replace wear parts at appropriate times, is not covered by this warranty. Any damage due to excessive loading is not covered by this warranty.

The use of products or components under load such that they reach the end of their expected life is a normal characteristic of the application of mechanical products. Reaching the end of a product’s expected life does not indicate any defect in material or workmanship and is not covered by this warranty.

Costs for shipment of units returned to the factory for warranty repairs are the responsibility of the owner of the product. Exlar will return ship all warranty repairs or replacements via UPS Ground at no cost to the customer.

For international customers, Exlar will return ship warranty repairs or replacements via UPS Expedited Service and cover the associated shipping costs. Any VAT or local country taxes are the responsibility of the owner of the product.

The foregoing warranty is in lieu of all other warranties (except as Title), whether expressed or implied, including without limitation, any warranty of merchantability, or of fitness for any particular purpose, other than as expressly set forth and to the extent specified herein, and is in lieu of all other obligations or liabilities on the part of Exlar.

Seller’s maximum liability with respect to these terms and conditions and any resulting sale, arising from any cause whatsoever, including without limitation, breach of contract or negligence, shall not exceed the price specified herein of the product(s) giving rise to the claim, and in no event shall Exlar be liable under this warranty otherwise for special, incidental or consequential damages, whether similar or dissimilar, of any nature arising or resulting from the purchase, installation, removal, repair, operation, use or breakdown of the product(s) or any other cause whatsoever, including negligence.

The foregoing warranty shall also apply to products or parts which have been repaired or replaced pursuant to such warranty, and within the period of time, in accordance with Seller’s stated warranty.

NO PERSON, INCLUDING ANY AGENT OR REPRESENTATIVE OF EXLAR, IS AUTHORIZED TO MAKE ANY REPRESENTATION OR WARRANTY ON BEHALF OF EXLAR CONCERNING ANY PRODUCTS MANUFACTURED BY EXLAR, EXCEPT TO REFER PURCHASERS TO THIS WARRANTY.

About Curtiss-Wright Commercial / Industrial Segment

Curtiss-Wright provides highly engineered products and services with a focus on advanced technologies for high performance platforms and critical applications. Our technological expertise spans decades of innovation and we have compiled an extensive portfolio of critical technologies serving commercial, defense, energy and industrial markets. Our technologies, some that are sole source or first-of-a-kind, achieve the demanding performance levels required for optimal safety, performance and reliability in difficult “must not fail” applications.

USA – EXLAR AUTOMATION
Curtiss-Wright

18400 West 77th Street
Chanhassen, MN 55317
Phone: 855-620-6200 (US & Canada)
Phone: 952-500-6200
Email: CHA_info@curtisswright.com
Website: www.exlar.com

EUROPE – EXLAR EUROPE GmbH
Curtiss-Wright

Schleißheimer Str., 91a
Garching bei München D-85748
Germany
Phone: +49 6184 994730
Email: info@exlar.de
Website: www.exlar.com/de/

ASIA – EXLAR ASIA PACIFIC
Curtiss-Wright

1007 Pine City Hotel
8 Dong An Road, Xuhui District
Shanghai 200032 China
Phone: +86 021-6495-7868
Email: mfan@curtisswright.cn
Website: www.exlar.com/zh-hans/