

## SP+ B5

### Motoranbauanleitung Motormounting instructions Instruction d'assemblage du moteur

WITTENSTEIN alpha GmbH  
Walter-Wittenstein-Str. 1  
97999 Igersheim / Germany  
www.wittenstein-alpha.de  
Tel. +49 7931 493-0  
Fax. +49 7931 493-200  
Dok-Nr. 2022-D013073-07

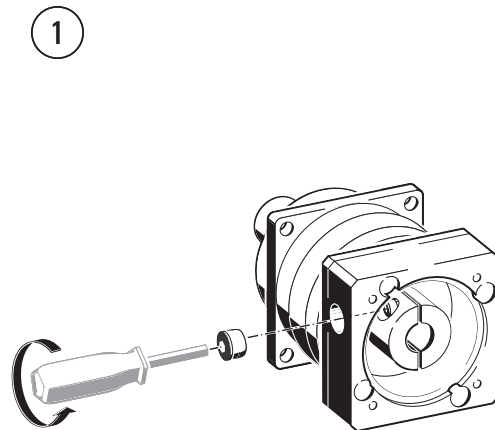

- Verschlusschraube lösen und aufbewahren
- Release plug and reserve
- Desserrer le bouchon obturateur et le conserver
- Allentare e riporre il tappo a vite
- Soltar el tornillo de cierre y conservarlo
- Soltar parafuso de fechamento e guardá-lo

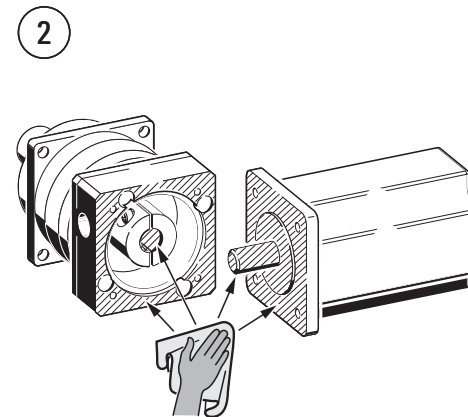

- Gründlich reinigen/entfetten – keine Pressluft verwenden
- Clean thoroughly/degrease – do not use compressed air
- Nettoyer entièrement/dégraissier – ne pas utiliser d'air comprimé
- Pulire accuratamente/sgrassare. Non usare aria compressa
- Limpiar a fondo/desengrasar – No usar aire comprimido
- Limpar criteriosamente/desengordurar – não usar ar comprimido

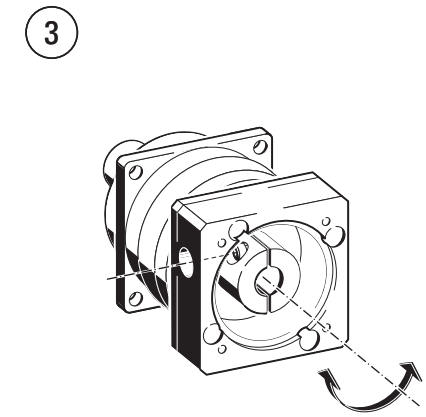

- Lagerichtig drehen
- Turn into correct position
- Tourner dans la bonne position
- Girare in posizione corretta
- Girarlo a la posición prescrita
- Girar para a posição correta



WITTENSTEIN

alpha

4

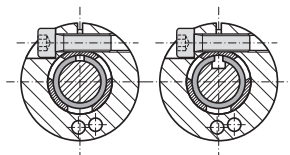

- Bei genuteter Motorwelle: Passfeder entfernen. Schlitz, Distanzhülse und Passfedernut lagerichtig montieren
- With grooved shaft: remove feather key. Mount slot, spacer sleeve and feather key groove in the correct position
- Pour les arbres de moteur cannelés: retirer la clavette. Monter la fente, la bague et la rainure pour clavette de manière à ce qu'elles se trouvent dans la bonne position
- Per alberi motore con chiavetta: rimuovere la chiavetta. Montare una mezza chiavetta, la bussola distanziale e posizionare la mezza chiavetta nella posizione corretta
- Si se trata de un eje de motor ranurado: saque la claveta. Montar de acuerdo a la posición prescrita la entalladura, el casquillo y la ranura de la claveta
- No caso de eixo do motor com ranhura: Remover chaveta. Montar fenda, manga distanciadora e chaveta na posição correta

5

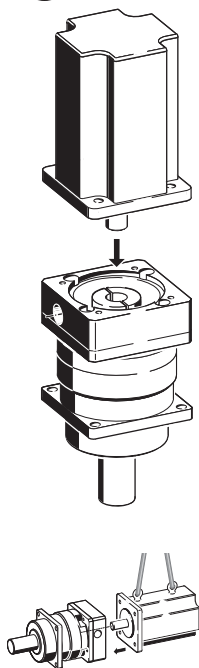

- ACHTUNG! Wenn Sie den Motor nicht leicht aufchieben können: Die Schraube in Bild 4 um eine Umdrehung lösen
- CAUTION! If the motor does not move into position easily: Loosen the screw in fig. 4 by one rotation
- ATTENTION !! Si le moteur ne peut pas être légèrement poussé: desserrer d'un tour la vis illustrée sur la figure 4
- ATTENZIONE! Se risultasse difficoltoso portare il motore in posizione: allentare di un giro la vite in figura 4
- ¡ATENCIÓN! Si al montar el motor no puede deslizarlo con facilidad: suelte una vuelta el tornillo de la figura 4
- ATENÇÃO! Caso não consiga colocar o motor facilmente: Soltar o parafuso da figura 4 por um giro

6

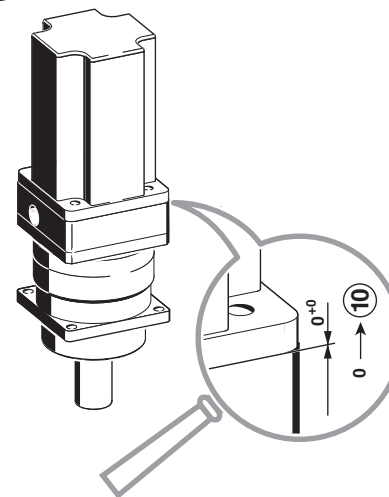

7

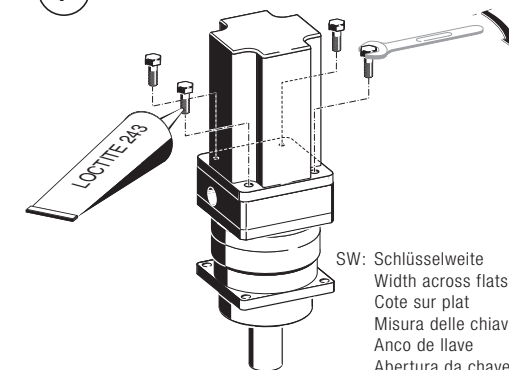

SW: Schlüsselweite  
Width across flats  
Cote sur plat  
Misura delle chiavi  
Anco de llave  
Abertura da chave

T<sub>A</sub>: Anzugsdrehmoment  
Tightening torque  
Couple de serrage  
Coppia di serraggio  
Par de apriete  
Torque de aperto



WITTENSTEIN

alpha

8

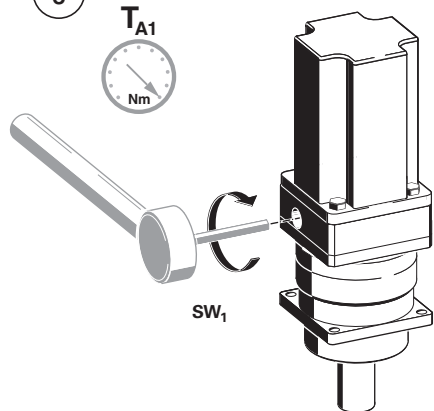

SW <sub>1</sub> [mm]	T <sub>A1</sub> [Nm]
3	4,1
4	9,5
5	16
6	39
8	79
10	135
14	330

9

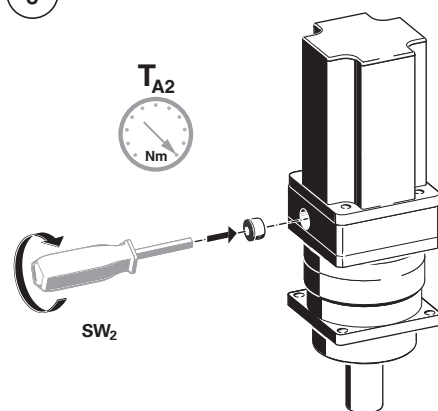

SW <sub>2</sub> [mm]	T <sub>A2</sub> [Nm]
5	10
8	35
10	50
12	70

10

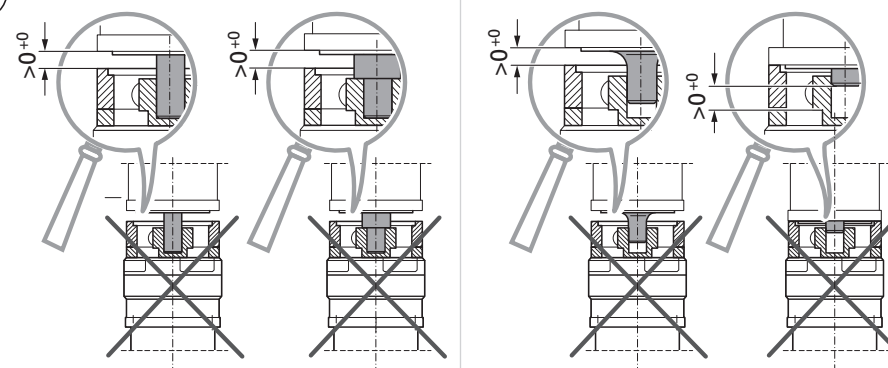

- |  |   |   |  |   |
|--|---|---|--|---|
| <b>Motorwelle:</b><br><b>Motor shaft:</b><br><b>Arbre de moteur:</b><br><b>Eje del motor:</b><br><b>Eixo do motor:</b> | zu lang<br>too long<br>trop long<br>troppo lungo<br>demasiado largo<br>longo demais | mit Absatz<br>with shoulder<br>avec palier<br>con spallamento<br>con quebrada<br>com degrau | mit Radius<br>with radius<br>avec rayon<br>con raggio<br>con radio<br>com raio | zu kurz<br>too short<br>trop court<br>troppo corto<br>demasiado corto<br>curto demais |
|--|---|---|--|---|

- ACHTUNG!  
In diesen Fällen in der Betriebsanleitung nachlesen
- CAUTION!  
In these cases, look up instructions in the operating manual
- ATTENTION!  
Si ces cas se présentent, consulter le manuel d'utilisation
- ATTENZIONE!  
In questi casi leggere il manuale operativo
- ¡ATENCIÓN!  
En estos casos, consultar las instrucciones de servicio
- ATENÇÃO!  
Nestes casos, consultar as Instruções de operação